

PLANT LIST

SYMBOL	BOTANICAL NAME	COMMON NAME	SPACING	SIZE	TOTAL
2U	AUCUBA JAPONICA	JAPANESE AUCUBA	AS SHN	27cm POT	1
2Z	AZALEA JAPONICA (ASSORTED)	JAPANESE AZALEA	2'-0" O.C.	15cm POT	7
CH	CHOSYIA TERNATA	MEXICAN MOCK ORANGE	AS SHN	21cm POT	3
CK	CORNUS KOUSA	CHINESE DOGWOOD	AS SHN	2.0m HT	5
ESC	ESCALLONIA 'NEWPORT DWARF'	DWARF ESCALLONIA	2'-6" O.C.	15cm POT	24
EVO	EUONYMUS AUREO-MARGINATA	GOLDEN EUONYMUS	AS SHN	21cm POT	4
EU	EUONYMUS FORTUNEI 'EMERALD GAITY'	EUONYMUS	2'-0" O.C.	15cm POT	10
MA	MANTONIA AQUIFOLIUM	OREGON GRAPE	2'-0" O.C.	21cm POT	7
NA	NANDINA DOMESTICA	HEAVENLY BAMBOO	2'-6" O.C.	21cm POT	8
PJ	PIERIS JAPONICA 'MOUNTAIN FIRE'	LILY-OF-THE-VALLEY SHRUB	AS SHN	21cm POT	3
CF	CORNUS FLORIDA PUBRA	PINK DOGWOOD	AS SHN	2.0m HT	1
CH1	RHODODENDRON CREAM CREST	RHODODENDRON	AS SHN	21cm POT	2
CH2	RHODODENDRON 'FLM'	RHODODENDRON	AS SHN	21cm POT	1
CH3	RHODODENDRON DORA AMATELIS	RHODODENDRON	AS SHN	21cm POT	1
SK	SKIMMIA JAPONICA	SKIMMIA	2'-6" O.C.	21cm POT	5
VD	VIBURNUM DAVIDII	DAVID'S VIBURNUM	2'-6" O.C.	15cm POT	3

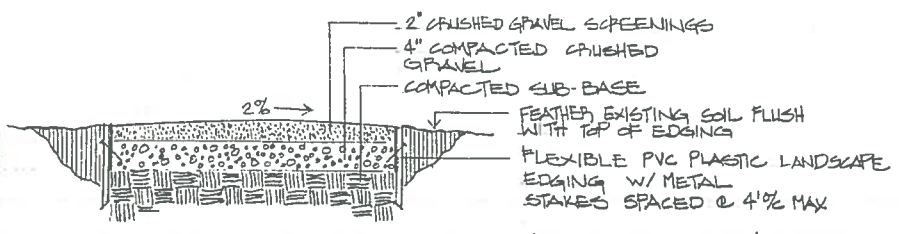
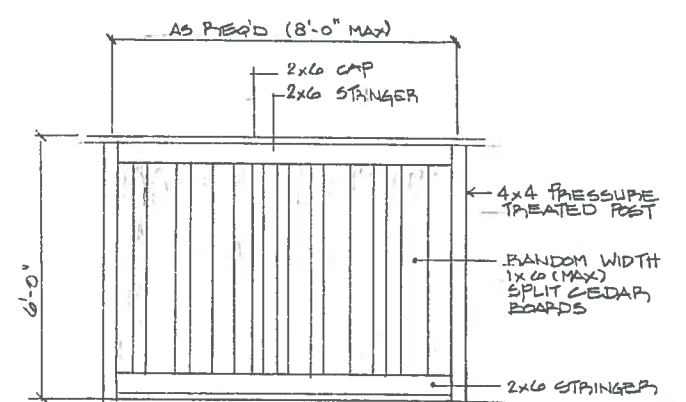
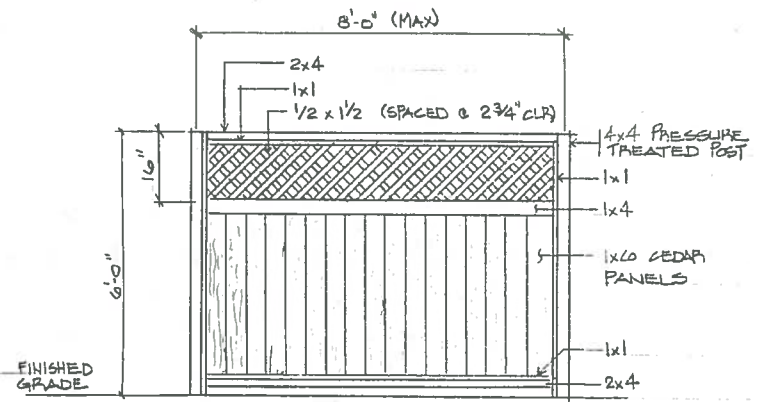
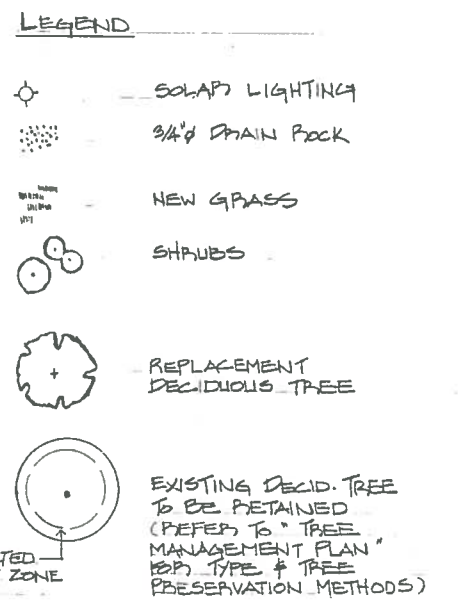

- ### GENERAL NOTES
- REFER TO "TREE MANAGEMENT PLAN" FOR TYPES OF EXISTING TREES THAT WILL BE RETAINED & TREE PRESERVATION MEASURES
 - ALL LANDSCAPING SHALL CONFORM TO BCSLA / BCNTA LANDSCAPE STANDARD
 - FINAL GRADES SHALL MATCH EXISTING GRADES AT PROPERTY BOUNDARY
 - ALL LANDSCAPED AREAS AT NEW RESIDENCES SHALL BE IRRIGATED WITH PROFESSIONALLY INSTALLED AUTOMATIC UNDERGROUND SYSTEM
 - CRUSHED GRAVEL SCREENINGS WALKWAY SHALL CONSIST OF: 2" CRUSHED GRAVEL SCREENINGS 4" COMPACTED GRANULAR BASE COMPACTED SUB-BASE
 - PAVED STEPS (AT PATIO) SHALL CONSIST OF: 4" HIGH TREADS 12" DEEP TREADS
 - LOW RETAINING WALL @ PATIO SHALL BE CONSTRUCTED OF 4x4 PRESSURE TREATED LANDSCAPE TIES
 - PHOTOGRAPHS OF EXISTING FENCES ALONG NORTH & SOUTH PROPERTY LINES ARE LOCATED ON ARCH. DWGS

LANDSCAPE PLAN

GARDEN SUITE FOR SHAMILE GONDAL 2540 TRENT ST SAANICH B.C.	
SCALE: 1:100	LI #1
DATE: NOV 2021	
DOUG MCLEAN, O.D.H. LANDSCAPE DESIGN 839 SWAN ST VICTORIA B.C. V8X 2Z2 (250) 475-0723	

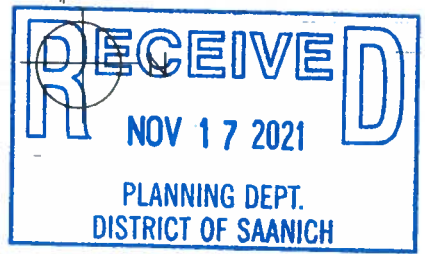

2540 TRENT STREET

LANDSCAPE PLAN
SCALE: 1:100