

Morris Drive @ Lucas Avenue

Wednesday, September 19, 2018



The data presented here is for information purposes only and should not be considered authoritative for construction, geotechnical, engineering, navigational, legal, or other site-specific uses. The information shared is owned by the Transportation Division of the Engineering Department at the District of Saanich. Accuracy is not guaranteed.

DISTRICT OF SAANICH 2018 TRAFFIC COUNTS

Major Route: Morris Drive
Minor Route: Lucas Avenue
Date: Wednesday, September 19, 2018
Filename: Morris@Lucas-Sep19-2018.xls

Station #: TIN000993
Intersection Type: 4-leg
East/West Route: Lucas Avenue
Weather: Clear and dry

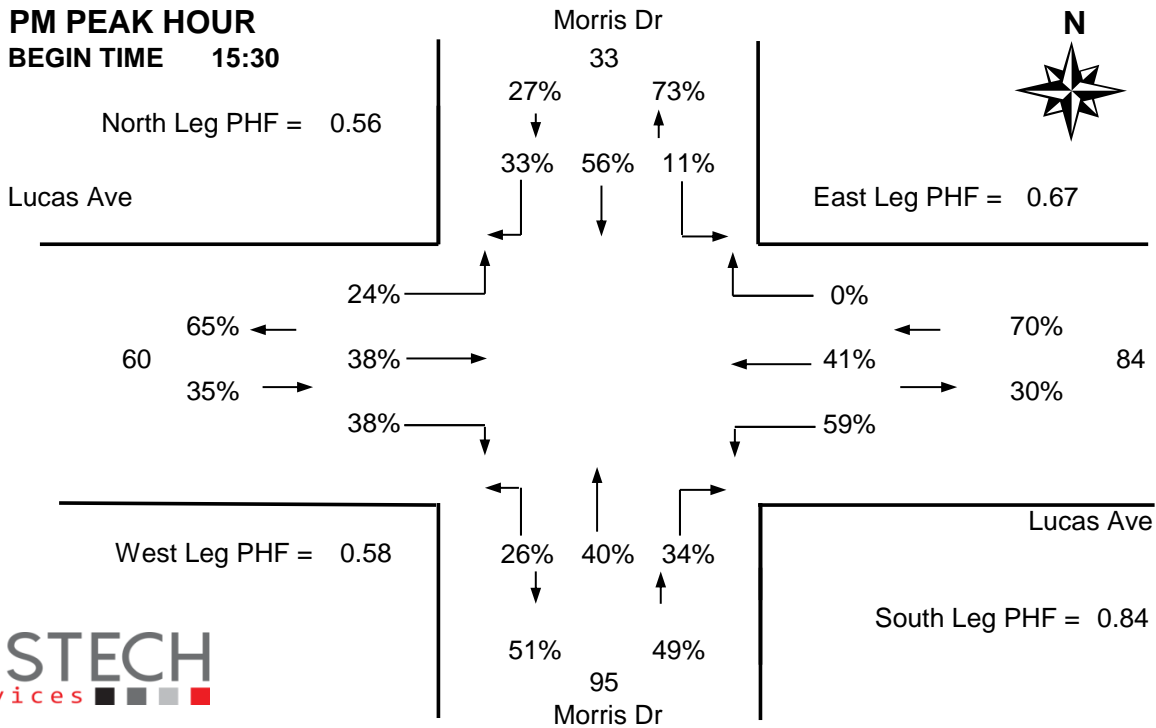
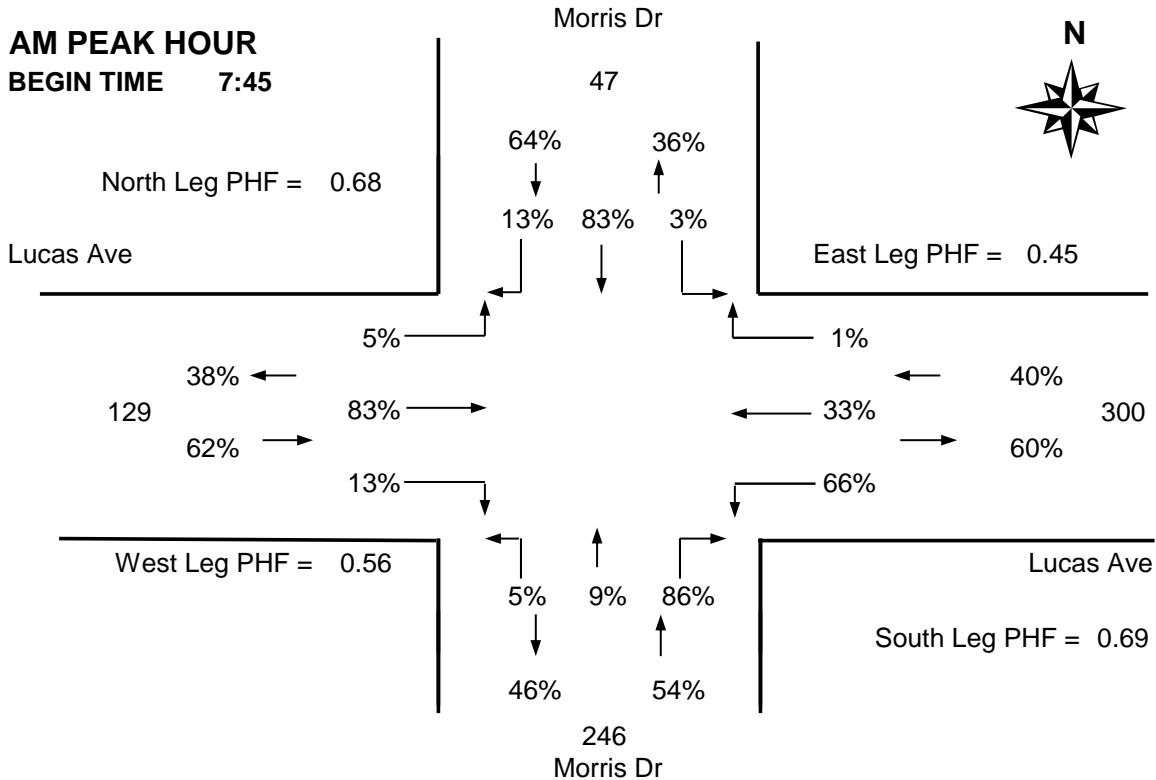

DISTRICT OF SAANICH 2018 TRAFFIC COUNTS

Major Route: Morris Drive
Minor Route: Lucas Avenue
Date: Wednesday, September 19, 2018
Filename: Morris@Lucas-Sep19-2018.xls

Station #: TIN000993
Intersection Type: 4-leg
East/West Route: Lucas Avenue
Weather: Clear and dry

Comments: Count ID-2018150

Vehicle Data

Time Period Starting	Morris Dr			Morris Dr			Lucas Ave			Lucas Ave			15 Min Total	Hourly Total	Pedestrians			
	From North			From South			From West			From East					N	S	W	E
	Left	Thru	Right	Left	Thru	Right	Left	Thru	Right	Left	Thru	Right						
7:30	0	4	4	0	2	4	0	5	4	2	2	0	27	-	0	2	0	3
7:45	1	10	0	0	0	18	2	4	2	2	1	1	41 *	-	0	3	2	3
8:00	0	7	0	2	1	29	0	21	4	9	4	0	77 *	-	0	3	1	5
8:15	0	2	1	0	6	42	2	32	2	22	14	0	123 +	268	0	13	0	9
8:30	0	6	3	4	5	25	0	9	2	46	20	0	120 *	361	0	18	0	31
8:45	0	4	1	2	3	5	0	2	2	6	9	0	34	354	0	1	0	7
9:00	0	4	1	2	0	4	1	0	3	3	2	0	20	297	0	1	0	0
9:15	0	1	0	4	0	4	0	2	2	6	2	0	21	195	0	2	2	1
Total	1	38	10	14	17	131	5	75	21	96	54	1	463	-	0	43	5	59
Pk Hr	1	25	4	6	12	114	4	66	10	79	39	1	361 *	-	0	37	3	48
Pk Hr Factor	0.25	0.63	0.33	0.38	0.50	0.68	0.50	0.52	0.63	0.43	0.49	0.25	0.73	* = Peak hour + = Peak 15 minutes				
	0.68			0.69			0.56			0.45								
15:30	0	3	1	4	5	2	1	4	4	13	9	0	46 +	-	0	0	1	1
15:45	0	1	1	4	4	6	2	1	3	5	7	0	34 *	-	0	1	1	1
16:00	0	0	0	2	4	4	0	0	0	8	7	0	25 *	-	0	3	0	1
16:15	1	1	1	2	6	4	2	3	1	9	1	0	31 *	136	0	1	0	2
16:30	0	1	0	2	2	5	2	3	3	9	4	1	32	122	0	2	0	4
16:45	0	4	0	4	2	9	0	1	2	8	3	0	33	121	0	1	1	0
17:00	0	3	0	3	5	4	1	4	3	10	3	0	36	132	0	2	3	2
17:15	1	3	0	3	7	9	1	1	1	3	2	0	31	132	0	0	1	0
Total	2	16	3	24	35	43	9	17	17	65	36	1	268	-	0	10	7	11
Pk Hr	1	5	3	12	19	16	5	8	8	35	24	0	136 *	-	0	5	2	5
Pk Hr Factor	0.25	0.42	0.75	0.75	0.79	0.67	0.63	0.50	0.50	0.67	0.67	n/a	0.74					
	0.56			0.84			0.58			0.67								

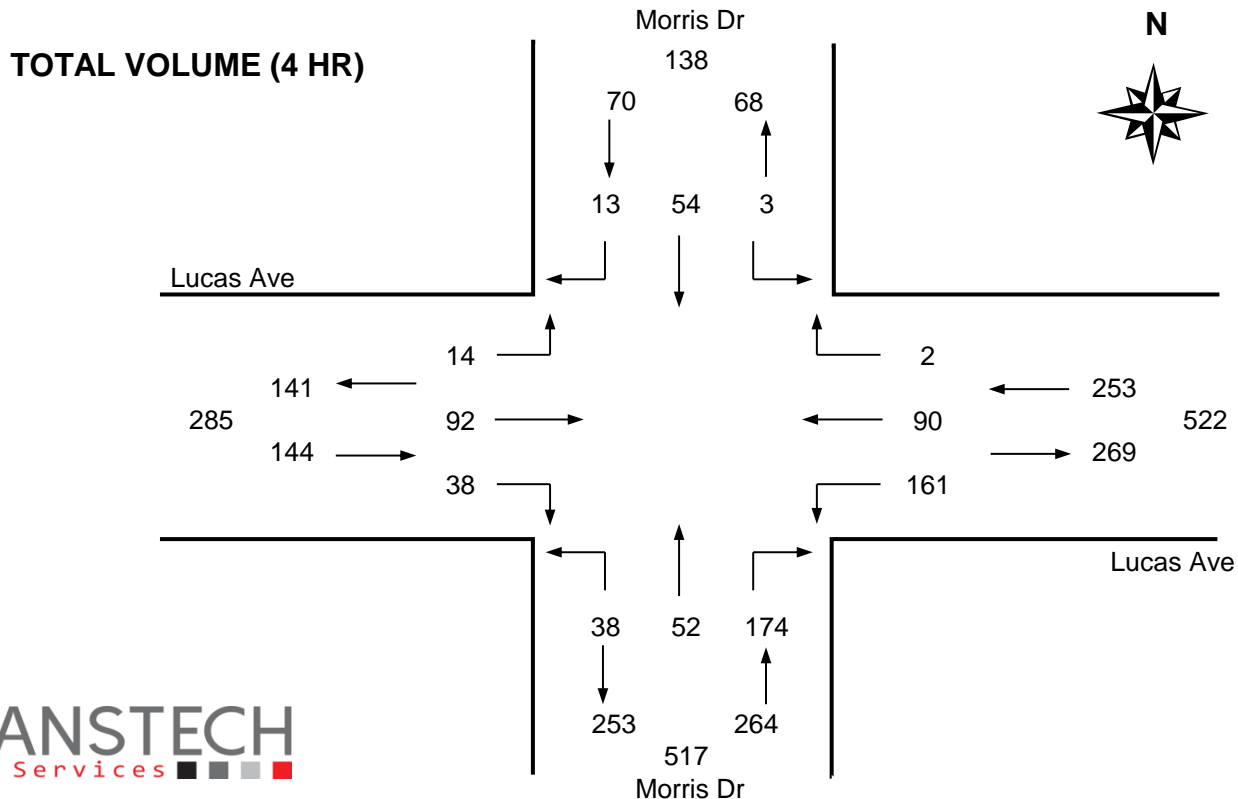

DISTRICT OF SAANICH 2018 TRAFFIC COUNTS

Major Route: Morris Drive
Minor Route: Lucas Avenue
Date: Wednesday, September 19, 2018
Filename: Morris@Lucas-Sep19-2018.xls

Station #: TIN000993
Intersection Type: 4-leg
East/West Route: Lucas Avenue
Weather: Clear and dry

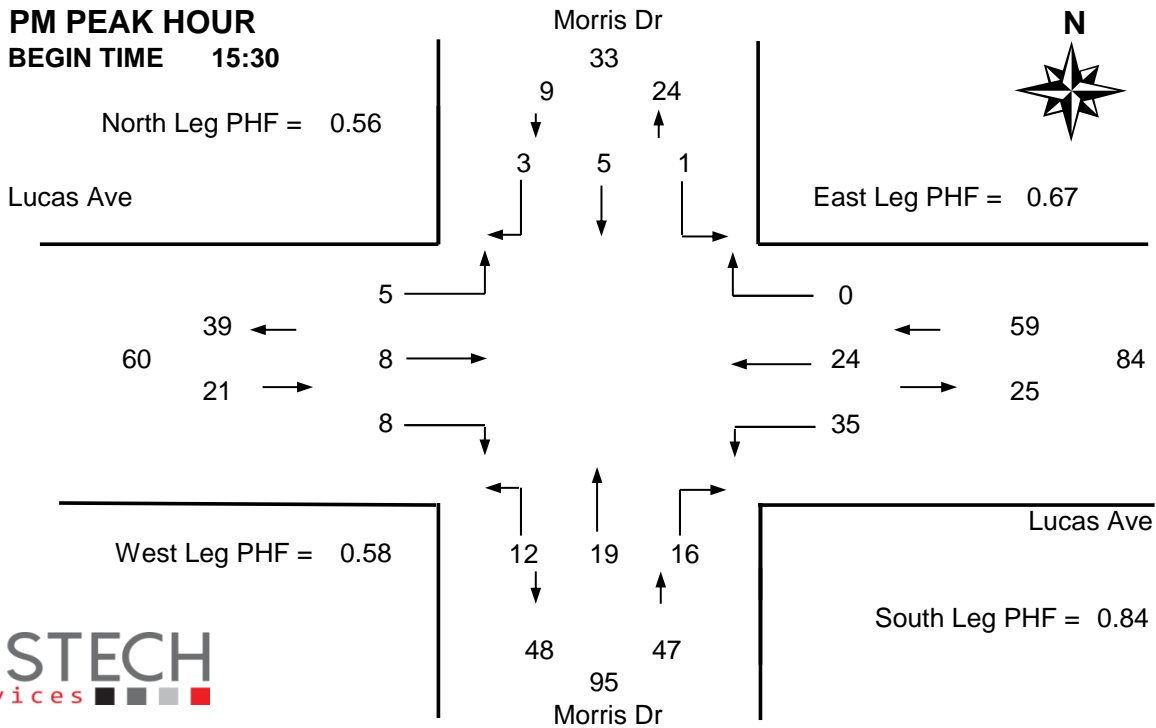
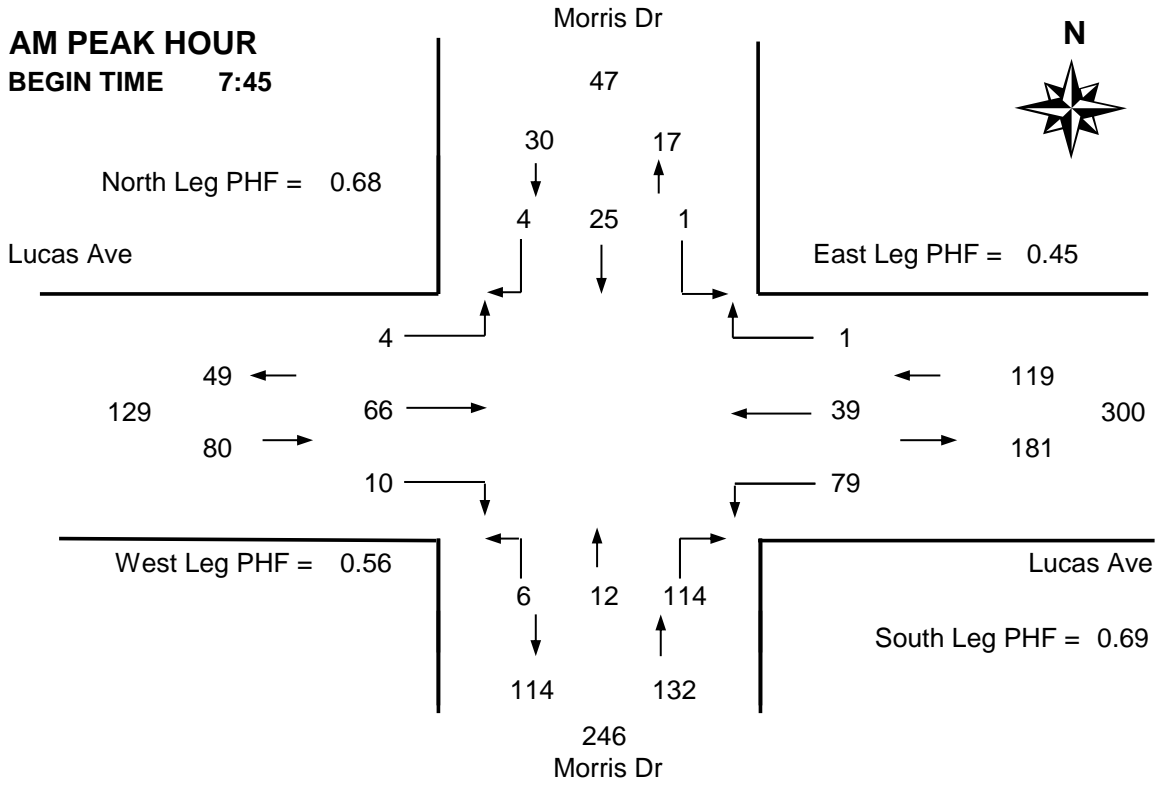

DISTRICT OF SAANICH 2018 TRAFFIC COUNTS

Major Route: Morris Drive
Minor Route: Lucas Avenue
Date: Wednesday, September 19, 2018
Filename: Morris@Lucas-Sep19-2018.xls

Station #: TIN000993
Intersection Type: 4-leg
East/West Route: Lucas Avenue
Weather: Clear and dry

Comments: Count ID-2018150

Bicycle Data

Time Period Starting	Morris Dr			Morris Dr			Lucas Ave			Lucas Ave			15 Min Total	Hourly Total
	From North			From South			From West			From East				
	Left	Thru	Right	Left	Thru	Right	Left	Thru	Right	Left	Thru	Right		
7:30	0	0	0	0	0	0	0	0	0	0	0	0	0	-
7:45	0	0	0	0	0	0	0	1	0	0	0	0	1 *	-
8:00	0	0	0	0	0	0	0	9	0	0	2	0	11 +	-
8:15	0	0	0	0	0	0	0	2	1	0	1	0	4 *	16
8:30	0	0	0	0	0	0	0	1	3	2	2	0	8 *	24
8:45	0	0	0	0	0	0	0	0	0	0	1	0	1	24
9:00	0	1	0	0	0	0	0	2	0	0	0	0	3	16
9:15	0	0	0	0	0	0	0	0	0	0	0	0	0	12
Total	0	1	0	0	0	0	0	15	4	2	6	0	28	-
Pk Hr	0	0	0	0	0	0	0	13	4	2	5	0	24 *	-
15x4	0	0	0	0	0	0	0	36	12	8	8	0	44 +	-

15:30	0	0	0	0	0	1	0	0	1	0	1	0	3 *	-
15:45	0	0	0	2	0	0	0	1	1	0	0	0	4 *	-
16:00	0	1	0	1	0	0	0	0	0	0	3	0	5 +	-
16:15	0	0	0	1	0	0	0	2	1	0	0	0	4 *	16
16:30	0	0	0	0	0	0	0	1	0	0	1	0	2	15
16:45	0	0	0	0	0	0	0	0	0	0	1	0	1	12
17:00	1	0	0	1	2	0	0	1	0	0	1	2	8	15
17:15	0	0	0	1	0	0	0	2	1	0	1	0	5	16
Total	1	1	0	6	2	1	0	7	4	0	8	2	32	-
Pk Hr	0	1	0	4	0	1	0	3	3	0	4	0	16 *	-
15x4	0	4	0	8	0	4	0	8	4	0	12	0	20 +	-

4 Hr	1	2	0	6	2	1	0	22	8	2	14	2	60	120
------	---	---	---	---	---	---	---	----	---	---	----	---	----	-----

PEAK HOUR SUMMARY

