

# Kenmore Road @ Majestic Drive

Thursday, March 08, 2018



The data presented here is for information purposes only and should not be considered authoritative for construction, geotechnical, engineering, navigational, legal, or other site-specific uses. The information shared is owned by the Transportation Division of the Engineering Department at the District of Saanich. Accuracy is not guaranteed.

# DISTRICT OF SAANICH 2018 TRAFFIC COUNTS

**Major Route:** Kenmore Road  
**Minor Route:** Majestic Drive  
**Date:** Thursday, March 8, 2018  
**Filename:** Kenmore@Majestic-Mar8-2018.xls

**Station #:** TIN000540  
**Intersection Type:** 3-leg north approach  
**East/West Route:** Kenmore Road  
**Weather:** Cloudy and damp

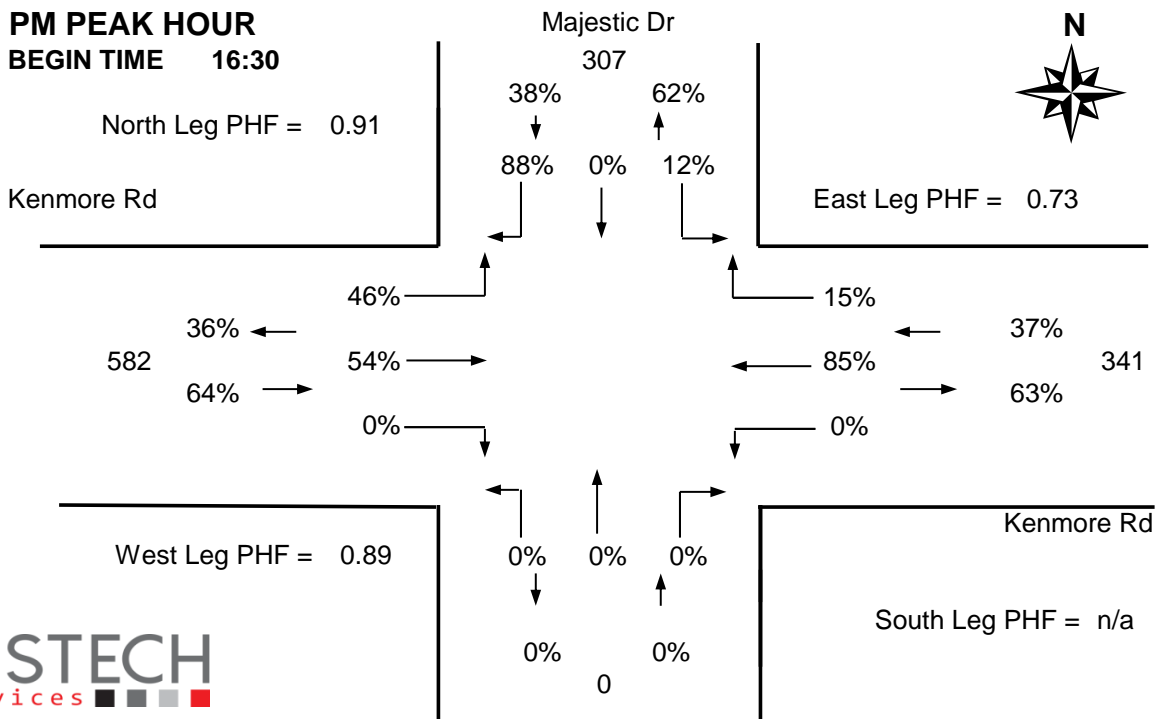
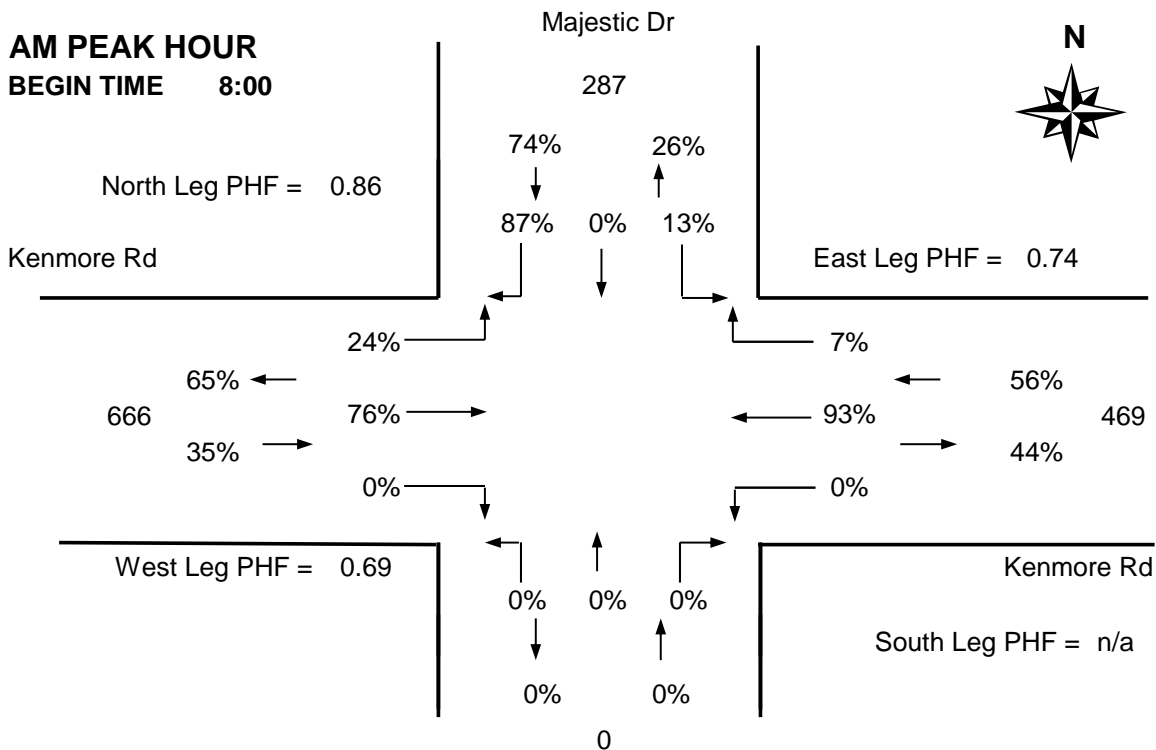

# DISTRICT OF SAANICH 2018 TRAFFIC COUNTS

**Major Route:** Kenmore Road  
**Minor Route:** Majestic Drive  
**Date:** Thursday, March 8, 2018  
**Filename:** Kenmore@Majestic-Mar8-2018.xls

**Station #:** TIN000540  
**Intersection Type:** 3-leg north approach  
**East/West Route:** Kenmore Road  
**Weather:** Cloudy and damp

**Comments:**

**Vehicle Data**

| Time Period Starting | Majestic Dr |            |             | From South |            |            | Kenmore Rd From West |             |            | Kenmore Rd From East |             |             | 15 Min Total | Hourly Total                         | Pedestrians |          |          |          |
|----------------------|-------------|------------|-------------|------------|------------|------------|----------------------|-------------|------------|----------------------|-------------|-------------|--------------|--------------------------------------|-------------|----------|----------|----------|
|                      | From North  |            |             | Left       | Thru       | Right      | Left                 | Thru        | Right      | Left                 | Thru        | Right       |              |                                      | N           | S        | W        | E        |
|                      | Left        | Thru       | Right       |            |            |            |                      |             |            |                      |             |             |              |                                      |             |          |          |          |
| 7:30                 | 2           |            | 36          |            |            |            | 6                    | 26          |            |                      | 58          | 1           | 129          | -                                    | 2           |          | 0        | 0        |
| 7:45                 | 4           |            | 35          |            |            |            | 8                    | 31          |            |                      | 43          | 3           | 124          | -                                    | 5           |          | 0        | 0        |
| 8:00                 | 5           |            | 48          |            |            |            | 5                    | 34          |            |                      | 59          | 1           | 152 *        | -                                    | 5           |          | 0        | 1        |
| 8:15                 | 9           |            | 51          |            |            |            | 13                   | 49          |            |                      | 57          | 5           | 184 *        | 589                                  | 1           |          | 0        | 0        |
| 8:30                 | 11          |            | 51          |            |            |            | 22                   | 63          |            |                      | 79          | 10          | 236 +        | 696                                  | 5           |          | 0        | 0        |
| 8:45                 | 2           |            | 36          |            |            |            | 16                   | 32          |            |                      | 51          | 2           | 139 *        | 711                                  | 1           |          | 0        | 0        |
| 9:00                 | 3           |            | 21          |            |            |            | 15                   | 21          |            |                      | 29          | 3           | 92           | 651                                  | 1           |          | 0        | 0        |
| 9:15                 | 3           |            | 23          |            |            |            | 9                    | 8           |            |                      | 18          | 3           | 64           | 531                                  | 3           |          | 0        | 0        |
| <b>Total</b>         | <b>39</b>   | <b>0</b>   | <b>301</b>  | <b>0</b>   | <b>0</b>   | <b>0</b>   | <b>94</b>            | <b>264</b>  | <b>0</b>   | <b>0</b>             | <b>394</b>  | <b>28</b>   | <b>1120</b>  | <b>-</b>                             | <b>23</b>   | <b>0</b> | <b>0</b> | <b>1</b> |
| <b>Pk Hr</b>         | <b>27</b>   | <b>0</b>   | <b>186</b>  | <b>0</b>   | <b>0</b>   | <b>0</b>   | <b>56</b>            | <b>178</b>  | <b>0</b>   | <b>0</b>             | <b>246</b>  | <b>18</b>   | <b>711 *</b> | <b>-</b>                             | <b>12</b>   | <b>0</b> | <b>0</b> | <b>1</b> |
| <b>Pk Hr Factor</b>  | <b>0.61</b> | <b>n/a</b> | <b>0.91</b> | <b>n/a</b> | <b>n/a</b> | <b>n/a</b> | <b>0.64</b>          | <b>0.71</b> | <b>n/a</b> | <b>n/a</b>           | <b>0.78</b> | <b>0.45</b> | <b>0.75</b>  | * = Peak hour<br>+ = Peak 15 minutes |             |          |          |          |
|                      | <b>0.86</b> |            |             | <b>n/a</b> |            |            | <b>0.69</b>          |             |            | <b>0.74</b>          |             |             |              |                                      |             |          |          |          |
| 15:30                | 1           |            | 14          |            |            |            | 34                   | 25          |            |                      | 32          | 5           | 111          | -                                    | 6           |          | 1        | 0        |
| 15:45                | 3           |            | 13          |            |            |            | 30                   | 47          |            |                      | 33          | 6           | 132          | -                                    | 0           |          | 0        | 0        |
| 16:00                | 4           |            | 17          |            |            |            | 19                   | 45          |            |                      | 34          | 4           | 123          | -                                    | 0           |          | 0        | 0        |
| 16:15                | 4           |            | 14          |            |            |            | 46                   | 31          |            |                      | 23          | 3           | 121          | 487                                  | 1           |          | 0        | 0        |
| 16:30                | 3           |            | 29          |            |            |            | 37                   | 49          |            |                      | 22          | 3           | 143 *        | 519                                  | 6           |          | 0        | 1        |
| 16:45                | 3           |            | 27          |            |            |            | 52                   | 53          |            |                      | 35          | 8           | 178 +        | 565                                  | 0           |          | 0        | 0        |
| 17:00                | 3           |            | 24          |            |            |            | 43                   | 43          |            |                      | 22          | 6           | 141 *        | 583                                  | 3           |          | 0        | 0        |
| 17:15                | 5           |            | 22          |            |            |            | 40                   | 56          |            |                      | 28          | 2           | 153 *        | 615                                  | 1           |          | 0        | 0        |
| <b>Total</b>         | <b>26</b>   | <b>0</b>   | <b>160</b>  | <b>0</b>   | <b>0</b>   | <b>0</b>   | <b>301</b>           | <b>349</b>  | <b>0</b>   | <b>0</b>             | <b>229</b>  | <b>37</b>   | <b>1102</b>  | <b>-</b>                             | <b>17</b>   | <b>0</b> | <b>1</b> | <b>1</b> |
| <b>Pk Hr</b>         | <b>14</b>   | <b>0</b>   | <b>102</b>  | <b>0</b>   | <b>0</b>   | <b>0</b>   | <b>172</b>           | <b>201</b>  | <b>0</b>   | <b>0</b>             | <b>107</b>  | <b>19</b>   | <b>615 *</b> | <b>-</b>                             | <b>10</b>   | <b>0</b> | <b>0</b> | <b>1</b> |
| <b>Pk Hr Factor</b>  | <b>0.70</b> | <b>n/a</b> | <b>0.88</b> | <b>n/a</b> | <b>n/a</b> | <b>n/a</b> | <b>0.83</b>          | <b>0.90</b> | <b>n/a</b> | <b>n/a</b>           | <b>0.76</b> | <b>0.59</b> | <b>0.86</b>  |                                      |             |          |          |          |
|                      | <b>0.91</b> |            |             | <b>n/a</b> |            |            | <b>0.89</b>          |             |            | <b>0.73</b>          |             |             |              |                                      |             |          |          |          |

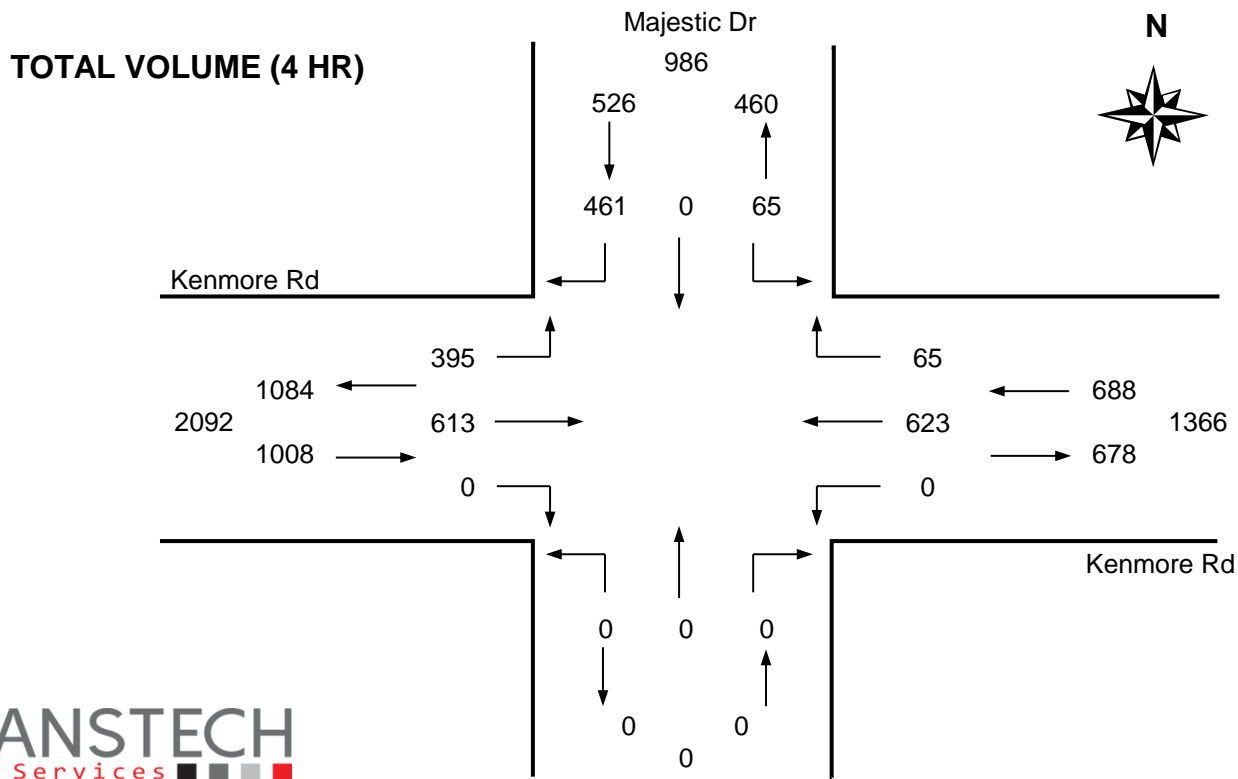

# DISTRICT OF SAANICH 2018 TRAFFIC COUNTS

**Major Route:** Kenmore Road  
**Minor Route:** Majestic Drive  
**Date:** Thursday, March 8, 2018  
**Filename:** Kenmore@Majestic-Mar8-2018.xls

**Station #:** TIN000540  
**Intersection Type:** 3-leg north approach  
**East/West Route:** Kenmore Road  
**Weather:** Cloudy and damp

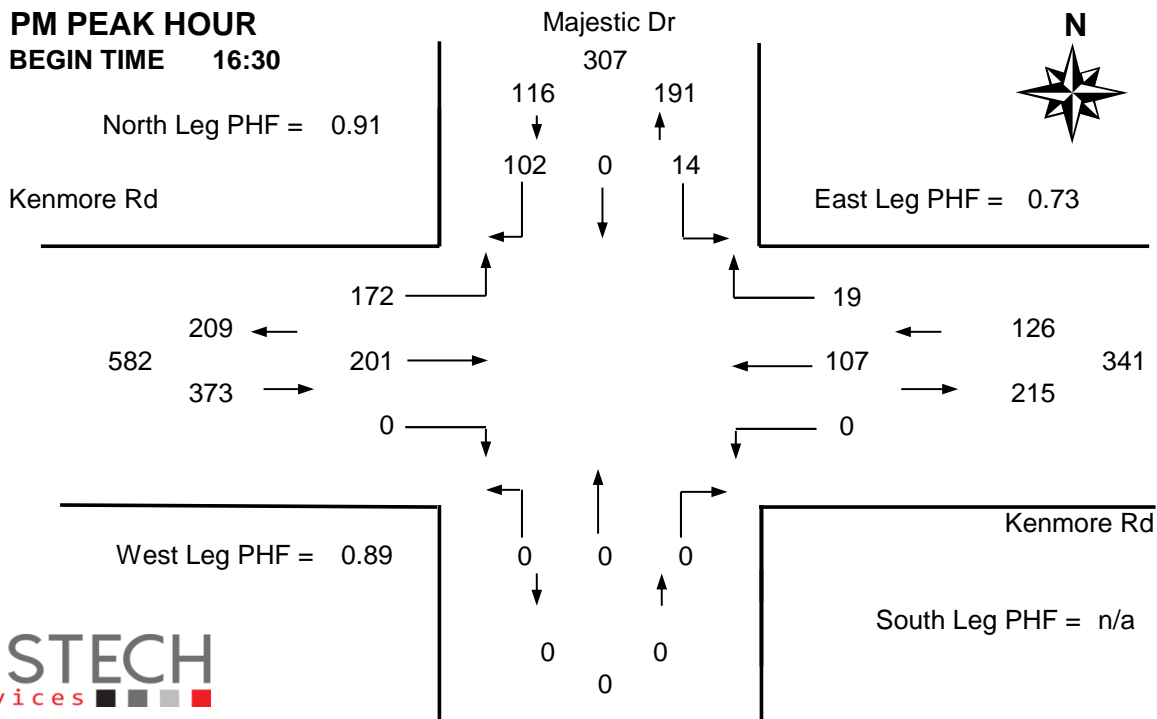
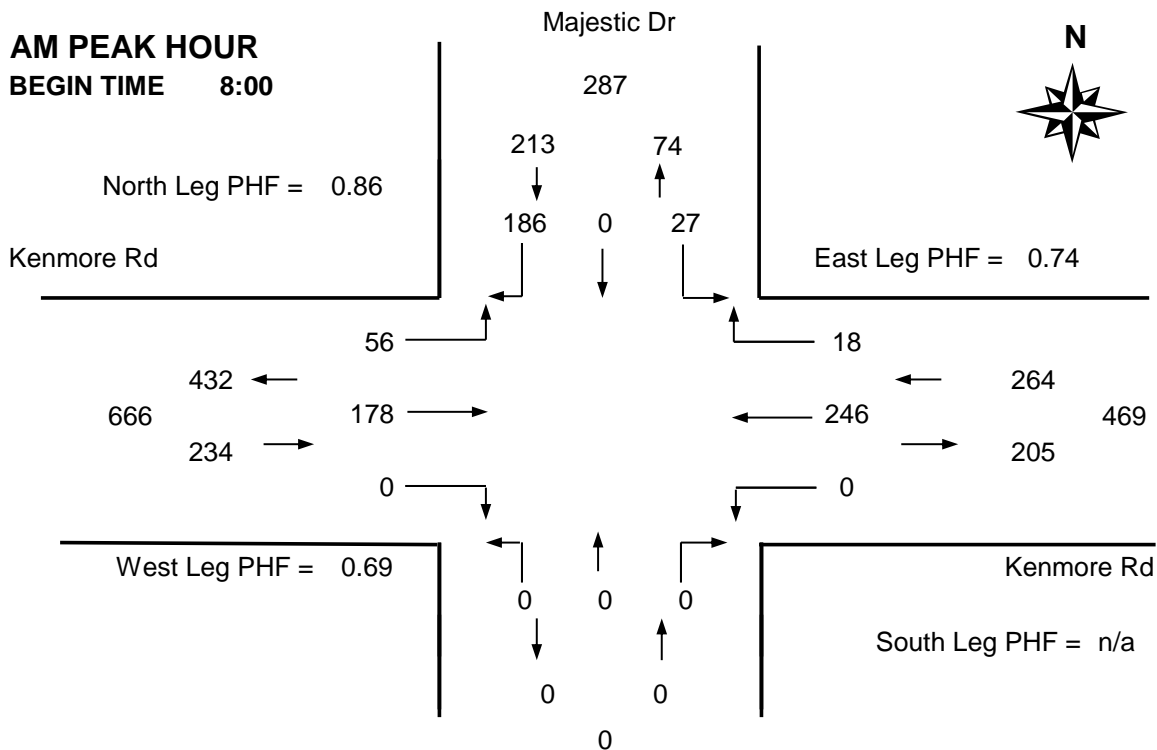

# DISTRICT OF SAANICH 2018 TRAFFIC COUNTS

**Major Route:** Kenmore Road  
**Minor Route:** Majestic Drive  
**Date:** Thursday, March 8, 2018  
**Filename:** Kenmore@Majestic-Mar8-2018.xls

**Station #:** TIN000540  
**Intersection Type:** 3-leg north approach  
**East/West Route:** Kenmore Road  
**Weather:** Cloudy and damp

**Comments:**

**Bicycle Data**

| Time Period Starting | Majestic Dr |          |          |            |          |          | Kenmore Rd |          |          | Kenmore Rd |          |          | 15 Min Total | Hourly Total |
|----------------------|-------------|----------|----------|------------|----------|----------|------------|----------|----------|------------|----------|----------|--------------|--------------|
|                      | From North  |          |          | From South |          |          | From West  |          |          | From East  |          |          |              |              |
|                      | Left        | Thru     | Right    | Left       | Thru     | Right    | Left       | Thru     | Right    | Left       | Thru     | Right    |              |              |
| 7:30                 | 1           |          | 0        |            |          |          | 0          | 0        |          |            | 1        | 0        | 2            | -            |
| 7:45                 | 1           |          | 0        |            |          |          | 0          | 0        |          |            | 0        | 0        | 1            | -            |
| 8:00                 | 0           |          | 0        |            |          |          | 0          | 1        |          |            | 1        | 0        | 2 *          | -            |
| 8:15                 | 2           |          | 0        |            |          |          | 0          | 0        |          |            | 0        | 0        | 2 *          | 7            |
| 8:30                 | 0           |          | 0        |            |          |          | 0          | 2        |          |            | 1        | 0        | 3 +          | 8            |
| 8:45                 | 2           |          | 0        |            |          |          | 0          | 0        |          |            | 0        | 0        | 2 *          | 9            |
| 9:00                 | 0           |          | 0        |            |          |          | 0          | 0        |          |            | 0        | 0        | 0            | 7            |
| 9:15                 | 0           |          | 1        |            |          |          | 0          | 0        |          |            | 0        | 0        | 1            | 6            |
| <b>Total</b>         | <b>6</b>    | <b>0</b> | <b>1</b> | <b>0</b>   | <b>0</b> | <b>0</b> | <b>0</b>   | <b>3</b> | <b>0</b> | <b>0</b>   | <b>3</b> | <b>0</b> | <b>13</b>    | <b>-</b>     |
| <b>Pk Hr</b>         | <b>4</b>    | <b>0</b> | <b>0</b> | <b>0</b>   | <b>0</b> | <b>0</b> | <b>0</b>   | <b>3</b> | <b>0</b> | <b>0</b>   | <b>2</b> | <b>0</b> | <b>9 *</b>   | <b>-</b>     |
| <b>15x4</b>          | <b>8</b>    | <b>0</b> | <b>0</b> | <b>0</b>   | <b>0</b> | <b>0</b> | <b>0</b>   | <b>8</b> | <b>0</b> | <b>0</b>   | <b>4</b> | <b>0</b> | <b>12 +</b>  | <b>-</b>     |

|              |          |          |          |          |          |          |          |          |          |          |          |          |            |          |
|--------------|----------|----------|----------|----------|----------|----------|----------|----------|----------|----------|----------|----------|------------|----------|
| 15:30        | 0        |          | 0        |          |          |          | 0        | 0        |          |          | 0        | 0        | 0          | -        |
| 15:45        | 0        |          | 0        |          |          |          | 0        | 0        |          |          | 0        | 0        | 0          | -        |
| 16:00        | 0        |          | 0        |          |          |          | 0        | 0        |          |          | 1        | 0        | 1          | -        |
| 16:15        | 0        |          | 0        |          |          |          | 1        | 0        |          |          | 0        | 0        | 1          | 2        |
| 16:30        | 0        |          | 0        |          |          |          | 0        | 1        |          |          | 0        | 0        | 1 *        | 3        |
| 16:45        | 0        |          | 0        |          |          |          | 0        | 0        |          |          | 0        | 1        | 1 *        | 4        |
| 17:00        | 0        |          | 0        |          |          |          | 0        | 0        |          |          | 0        | 1        | 1 *        | 4        |
| 17:15        | 0        |          | 0        |          |          |          | 1        | 0        |          |          | 0        | 1        | 2 +        | 5        |
| <b>Total</b> | <b>0</b> | <b>0</b> | <b>0</b> | <b>0</b> | <b>0</b> | <b>0</b> | <b>2</b> | <b>1</b> | <b>0</b> | <b>0</b> | <b>1</b> | <b>3</b> | <b>7</b>   | <b>-</b> |
| <b>Pk Hr</b> | <b>0</b> | <b>0</b> | <b>0</b> | <b>0</b> | <b>0</b> | <b>0</b> | <b>1</b> | <b>1</b> | <b>0</b> | <b>0</b> | <b>0</b> | <b>3</b> | <b>5 *</b> | <b>-</b> |
| <b>15x4</b>  | <b>0</b> | <b>0</b> | <b>0</b> | <b>0</b> | <b>0</b> | <b>0</b> | <b>4</b> | <b>4</b> | <b>0</b> | <b>0</b> | <b>0</b> | <b>4</b> | <b>8 +</b> | <b>-</b> |

|             |          |          |          |          |          |          |          |          |          |          |          |          |           |           |
|-------------|----------|----------|----------|----------|----------|----------|----------|----------|----------|----------|----------|----------|-----------|-----------|
| <b>4 Hr</b> | <b>6</b> | <b>0</b> | <b>1</b> | <b>0</b> | <b>0</b> | <b>0</b> | <b>2</b> | <b>4</b> | <b>0</b> | <b>0</b> | <b>4</b> | <b>3</b> | <b>20</b> | <b>40</b> |
|-------------|----------|----------|----------|----------|----------|----------|----------|----------|----------|----------|----------|----------|-----------|-----------|

**PEAK HOUR SUMMARY**

