

Interurban Road @ Marigold Road

Thursday, October 17, 2019



The data presented here is for information purposes only and should not be considered authoritative for construction, geotechnical, engineering, navigational, legal, or other site-specific uses. The information shared is owned by the Transportation Division of the Engineering Department at the District of Saanich. Accuracy is not guaranteed.

Major Route: Interurban Road
Minor Route: Marigold Road
Municipality: Saanich
Filename: Interurban Rd @ Marigold Rd-Oct 17, 2019.xlsx
Location #: TIN001309
Count ID: 2019045
Date: October 17, 2019
Day-of-week: Thursday

East/West Route: Marigold Road
Intersection Type: 4-leg
Signalized?: Yes
Weather: Rain and wet

Vehicle Classifications: Vehicles and Peds
 Bikes

This data is for Vehicles and Peds

Shift	Start	End	Duration
AM	7:30	9:30	2.00
MD			
PM	15:30	18:30	3.00
Total	7:30	18:30	5.00

Notes: 24-hour clock used for reporting (15-minute increments)
 North Approach - southbound vehicles approaching intersection from the north
 15x4 - 15 min volume (from maximum 15 minute period of movement/approach in peak hour period [*]) x 4
 Pedestrians - N indicates pedestrians crossing north approach (east/west)

Comments:

Time Period Begins	Interurban Rd				Interurban Rd				Marigold Rd				Marigold Rd				Total Volume		Ped	Crosswalks			
	NORTH Approach				SOUTH Approach				WEST Approach				EAST Approach				15-min	Hour		N	S	W	E
	Left	Thru	Right	Total	Left	Thru	Right	Total	Left	Thru	Right	Total	Left	Thru	Right	Total							
7:30	2	98	12	112	25	57	18	100	9	56	52	117	21	39	0	60	389		+	0	24	2	14
7:45	3	123	4	130	22	51	18	91	5	44	48	97	22	41	0	63	381		*	0	8	2	1
8:00	7	80	9	96	7	50	15	72	5	48	54	107	13	29	0	42	317		*	0	9	0	0
8:15	1	84	4	89	9	45	10	64	7	31	35	73	6	13	1	20	246	1333	*	0	1	0	0
8:30	2	74	3	79	6	45	17	68	4	17	21	42	7	21	0	28	217	1161		0	2	1	1
8:45	0	64	5	69	10	51	10	71	4	19	12	35	10	18	0	28	203	983		2	2	1	2
9:00	0	62	5	67	6	64	11	81	2	16	8	26	9	11	0	20	194	860		1	1	0	0
9:15	1	44	3	48	13	51	12	76	6	13	14	33	11	11	0	22	179	793		1	2	3	1
n/a																							
n/a																							
n/a																							
n/a																							
n/a																							
n/a																							
n/a																							
n/a																							
n/a																							
n/a																							
n/a																							
n/a																							
Total	16	629	45	690	98	414	111	623	42	244	244	530	99	183	1	283	2126			4	49	9	19

n/a																							
n/a																							
n/a																							
n/a																							
n/a																							
n/a																							
n/a																							
n/a																							
n/a																							
n/a																							
n/a																							
n/a																							
n/a																							
n/a																							
n/a																							
n/a																							
n/a																							
Total																							

15:30	1	64	3	68	106	158	37	301	1	31	18	50	17	78	3	98	517			0	1	0	1
15:45	2	63	2	67	115	143	38	296	1	28	19	48	12	85	0	97	508		*	2	0	1	1
16:00	1	71	2	74	109	158	32	299	3	32	28	63	11	63	2	76	512		*	1	1	0	1
16:15	0	60	2	62	112	154	30	296	2	21	24	47	11	78	2	91	496	2033	*	4	4	1	3
16:30	0	81	4	85	112	173	23	308	7	19	22	48	22	65	0	87	528	2044	+	1	6	1	3
16:45	1	70	3	74	76	119	31	226	5	20	22	47	17	81	0	98	445	1981		3	4	1	0
17:00	0	63	4	67	44	74	25	143	7	14	10	31	12	34	1	47	288	1757		0	3	1	0
17:15	0	63	6	69	32	79	24	135	2	10	10	22	14	33	0	47	273	1534		0	8	1	0
17:30	1	63	5	69	25	72	15	112	4	11	20	35	19	14	0	33	249	1255		1	8	0	2
17:45	2	74	1	77	15	63	17	95	1	15	12	28	18	14	1	33	233	1043		1	2	0	3
18:00	3	53	3	59	12	57	22	91	6	11	10	27	11	9	0	20	197	952		0	0	1	0
18:15	1	44	5	50	19	65	18	102	3	6	8	17	14	17	0	31	200	879		4	1	1	1
n/a																							
n/a																							
n/a																							
n/a																							
n/a																							
n/a																							
n/a																							
n/a																							
Total	12	769	40	821	777	1315	312	2404	42	218	203	463	178	571	9	758	4446			17	38	8	15

Time Period Begins	Interurban Rd NORTH Approach				Interurban Rd SOUTH Approach				Marigold Rd WEST Approach				Marigold Rd EAST Approach				Total Volume		Total	Crosswalks				Conflict		
	Left	Thru	Right	Total	Left	Thru	Right	Total	Left	Thru	Right	Total	Left	Thru	Right	Total	15-min	Hour		N	S	W	E	15 min	Hr	
n/a																										
n/a																										
n/a																										
n/a																										
n/a																										
n/a																										
n/a																										
n/a																										
n/a																										
n/a																										
n/a																										
n/a																										
n/a																										
n/a																										
n/a																										
n/a																										
n/a																										
n/a																										
n/a																										
n/a																										
n/a																										
n/a																										
n/a																										
n/a																										
n/a																										
n/a																										
n/a																										
n/a																										
n/a																										
n/a																										
n/a																										

Total																								
Avg Hr																								

Peak hour of the intersection

Pk Hr																								
15x4																								
PHF																								

Peak hour of conflicting volumes for the intersection

Pk Hr																								
15x4																								
PHF																								

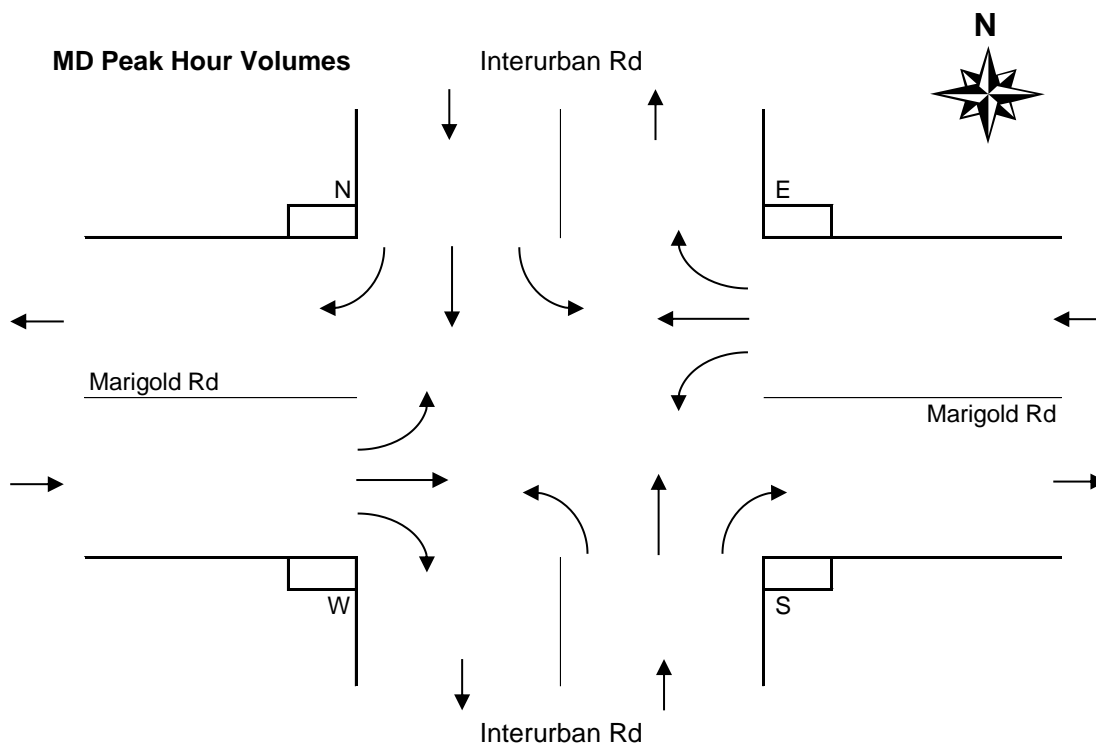

Time Period Begins	Interurban Rd				Interurban Rd				Marigold Rd				Marigold Rd				Total Volume		Veh/ Ped	Crosswalks				Conflict	
	NORTH Approach				SOUTH Approach				WEST Approach				EAST Approach				15-min	Hour		N	S	W	E	15 min	Hr
	Left	Thru	Right	Total	Left	Thru	Right	Total	Left	Thru	Right	Total	Left	Thru	Right	Total									
15:30	1	64	3	68	106	158	37	301	1	31	18	50	17	78	3	98	517		0	1	0	1	278		
15:45	2	63	2	67	115	143	38	296	1	28	19	48	12	85	0	97	508	*	2	0	1	1	269		
16:00	1	71	2	74	109	158	32	299	3	32	28	63	11	63	2	76	512	*	1	1	0	1	262		
16:15	0	60	2	62	112	154	30	296	2	21	24	47	11	78	2	91	496	2033*	4	4	1	3	266	1075	
16:30	0	81	4	85	112	173	23	308	7	19	22	48	22	65	0	87	528	2044+	1	6	1	3	269	1066	
16:45	1	70	3	74	76	119	31	226	5	20	22	47	17	81	0	98	445	1981	3	4	1	0	237	1034	
17:00	0	63	4	67	44	74	25	143	7	14	10	31	12	34	1	47	288	1757	0	3	1	0	153	925	
17:15	0	63	6	69	32	79	24	135	2	10	10	22	14	33	0	47	273	1534	0	8	1	0	138	797	
17:30	1	63	5	69	25	72	15	112	4	11	20	35	19	14	0	33	249	1255	1	8	0	2	143	671	
17:45	2	74	1	77	15	63	17	95	1	15	12	28	18	14	1	33	233	1043	1	2	0	3	135	569	
18:00	3	53	3	59	12	57	22	91	6	11	10	27	11	9	0	20	197	952	0	0	1	0	114	530	
18:15	1	44	5	50	19	65	18	102	3	6	8	17	14	17	0	31	200	879	4	1	1	1	112	504	
n/a																									
n/a																									
n/a																									
n/a																									
n/a																									
n/a																									
n/a																									
n/a																									
n/a																									
n/a																									

Total	12	769	40	821	777	1315	312	2404	42	218	203	463	178	571	9	758	4446								17	38	8	15	2261	
Avg Hr	4	256	13	274	259	438	104	801	14	73	68	154	59	190	3	253	1482									6	13	3	5	

Peak hour of the intersection

Pk Hr	3	275	10	288	448	628	123	1199	13	100	93	206	56	291	4	351	2044	*								8	11	3	8	1062	
15x4	8	324	16	340	460	692	152	1232	28	128	112	252	88	340	8	388	2112	+									16	24	4	12	1228
PHF	0.38	0.85	0.63	0.85	0.97	0.91	0.81	0.97	0.46	0.78	0.83	0.82	0.64	0.86	0.50	0.90	0.97										0.50	0.46	0.75	0.67	0.86

Peak hour of conflicting volumes for the intersection

Pk Hr	4	258	9	271	442	613	137	1192	7	112	89	208	51	304	7	362	2033	*								7	6	2	6	1072	
15x4	8	284	12	296	460	632	152	1204	12	128	112	252	68	340	12	392	2068	+									16	16	4	12	1156
PHF	0.50	0.91	0.75	0.92	0.96	0.97	0.90	0.99	0.58	0.88	0.79	0.83	0.75	0.89	0.58	0.92	0.98										0.44	0.38	0.50	0.50	0.93

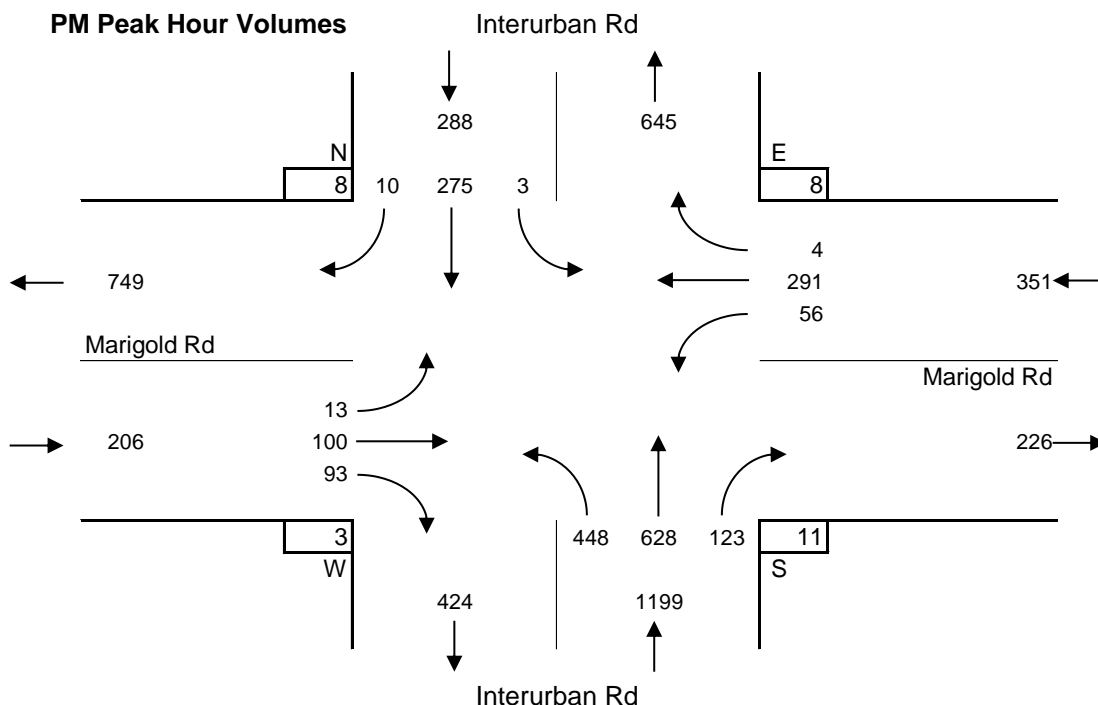

Entire Survey Period

5 Hours

	Interurban Rd				Interurban Rd				Marigold Rd				Marigold Rd				Total Volume	Crosswalks			
	NORTH Approach				SOUTH Approach				WEST Approach				EAST Approach					N	S	W	E
	Left	Thru	Right	Total	Left	Thru	Right	Total	Left	Thru	Right	Total	Left	Thru	Right	Total					
Total	28	1398	85	1511	875	1729	423	3027	84	462	447	993	277	754	10	1041	6572	21	87	17	34
Avg Hr	6	280	17	302	175	346	85	605	17	92	89	199	55	151	2	208	1314	4	17	3	7

AM Peak Period

2 Hours

	Interurban Rd				Interurban Rd				Marigold Rd				Marigold Rd				Total Volume	Crosswalks			
	NORTH Approach				SOUTH Approach				WEST Approach				EAST Approach					N	S	W	E
	Left	Thru	Right	Total	Left	Thru	Right	Total	Left	Thru	Right	Total	Left	Thru	Right	Total					
Totals	16	629	45	690	98	414	111	623	42	244	244	530	99	183	1	283	2126	4	49	9	19
Avg Hr	8	315	23	345	49	207	56	312	21	122	122	265	50	92	1	142	1063	2	25	5	10

MD Peak Period

Hours

	Interurban Rd				Interurban Rd				Marigold Rd				Marigold Rd				Total Volume	Crosswalks			
	NORTH Approach				SOUTH Approach				WEST Approach				EAST Approach					N	S	W	E
	Left	Thru	Right	Total	Left	Thru	Right	Total	Left	Thru	Right	Total	Left	Thru	Right	Total					
Total																					
Avg Hr																					

PM Peak Period

3 Hours

	Interurban Rd				Interurban Rd				Marigold Rd				Marigold Rd				Total Volume	Crosswalks			
	NORTH Approach				SOUTH Approach				WEST Approach				EAST Approach					N	S	W	E
	Left	Thru	Right	Total	Left	Thru	Right	Total	Left	Thru	Right	Total	Left	Thru	Right	Total					
Total	12	769	40	821	777	1315	312	2404	42	218	203	463	178	571	9	758	4446	17	38	8	15
Avg Hr	4	256	13	274	259	438	104	801	14	73	68	154	59	190	3	253	1482	6	13	3	5

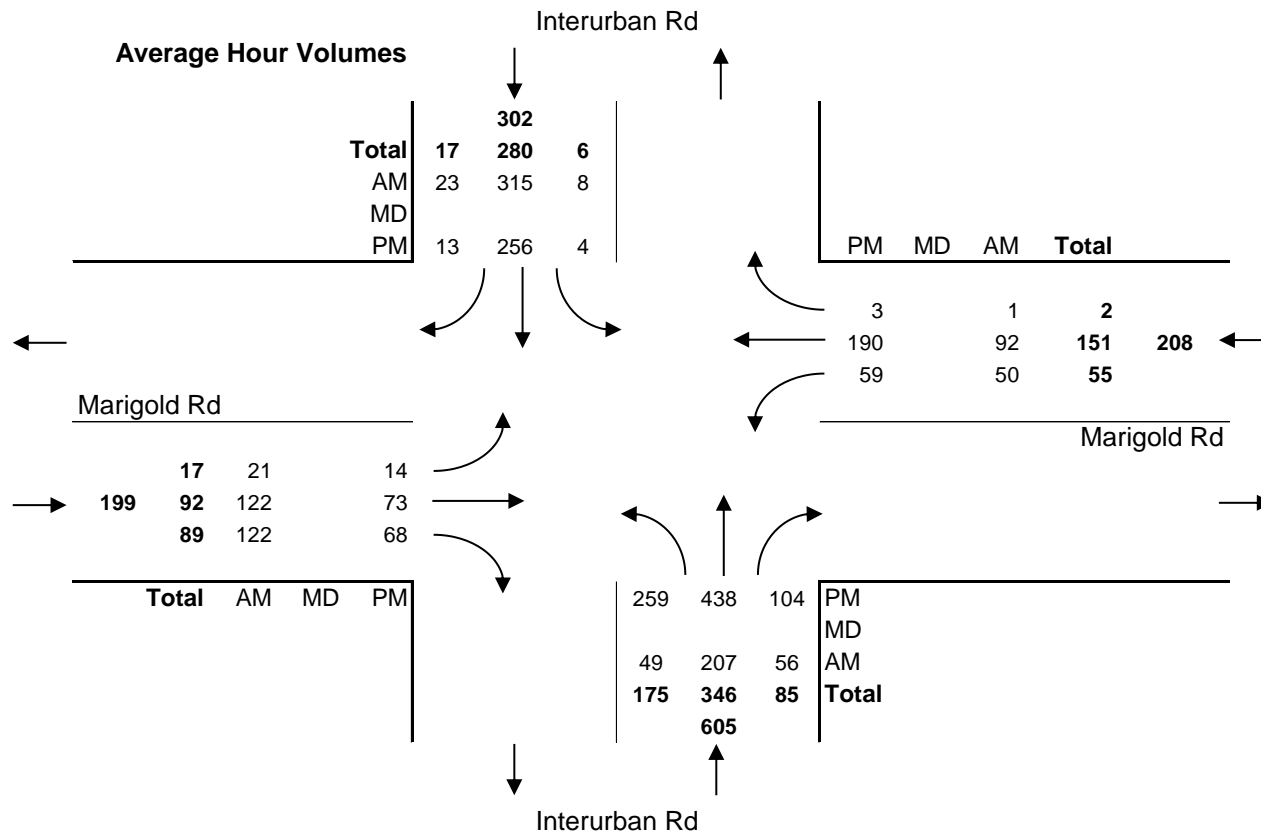

Major Route: Interurban Road
Minor Route: Marigold Road
Municipality: Saanich
Filename: Interurban Rd @ Marigold Rd-Oct 17, 2019.xlsx
Location #: TIN001309
Count ID: 2019045
Date: October 17, 2019
Day-of-week: Thursday

East/West Route: Marigold Road
Intersection Type: 4-leg
Signalized?: Yes
Weather: Rain and wet

Vehicle Classifications: Vehicles and Peds
 Bikes

This data is for Bikes

Shift	Start	End	Duration
AM	7:30	9:30	2.00
MD			
PM	15:30	18:30	3.00
Total	7:30	18:30	5.00

Notes: 24-hour clock used for reporting (15-minute increments)
 North Approach - southbound vehicles approaching intersection from the north
 15x4 - 15 min volume (from maximum 15 minute period of movement/approach in peak hour period [*]) x 4
 Pedestrians - N indicates pedestrians crossing north approach (east/west)

Comments:

Time Period Begins	Interurban Rd				Interurban Rd				Marigold Rd				Marigold Rd				Total Volume		Peak Period				
	NORTH Approach				SOUTH Approach				WEST Approach				EAST Approach				15-min	Hour		N	S	W	E
7:30	0	5	0	5	0	5	0	5	1	0	1	2	0	0	0	0	12		+	0	0	0	0
7:45	0	2	0	2	0	0	1	1	0	0	1	1	0	0	0	0	4		*	0	0	0	0
8:00	0	3	1	4	0	0	0	0	0	0	0	0	1	0	0	1	5		*	0	0	0	0
8:15	0	1	0	1	0	0	1	1	0	0	0	0	0	0	0	0	2	23	*	0	0	0	0
8:30	0	1	0	1	0	0	1	1	0	0	0	0	1	1	0	2	4	15		0	0	0	0
8:45	0	2	0	2	1	2	0	3	0	0	0	0	0	1	0	1	6	17		0	0	0	0
9:00	0	0	0	0	0	0	0	0	0	0	0	0	0	0	0	0	0	12		0	0	0	0
9:15	0	0	0	0	0	1	0	1	0	0	0	0	0	0	0	0	1	11		0	0	0	0
n/a																							
n/a																							
n/a																							
n/a																							
n/a																							
n/a																							
n/a																							
n/a																							
n/a																							
n/a																							
n/a																							
Total	0	14	1	15	1	8	3	12	1	0	2	3	2	2	0	4	34			0	0	0	0

n/a																							
n/a																							
n/a																							
n/a																							
n/a																							
n/a																							
n/a																							
n/a																							
n/a																							
n/a																							
n/a																							
n/a																							
n/a																							
n/a																							
n/a																							
Total																							

15:30	0	3	0	3	0	2	0	2	1	1	0	2	0	0	0	0	7			0	0	0	0
15:45	0	4	0	4	0	6	0	6	0	1	0	1	0	1	0	1	12		+	0	0	0	0
16:00	0	1	0	1	0	9	0	9	0	0	0	0	0	0	0	0	10		*	0	0	0	0
16:15	0	3	0	3	0	5	0	5	0	0	0	0	1	0	0	1	9	38	*	0	0	0	0
16:30	0	1	1	2	0	6	0	6	0	0	0	0	1	0	0	1	9	40	*	0	0	0	0
16:45	0	2	0	2	0	4	0	4	0	0	0	0	0	0	0	0	6	34		0	0	0	0
17:00	0	1	0	1	0	3	0	3	0	0	0	0	0	0	0	0	4	28		0	0	0	0
17:15	0	1	0	1	0	0	0	0	0	0	0	0	0	0	0	0	1	20		0	0	0	0
17:30	0	0	0	0	0	4	1	5	0	0	0	0	0	0	0	0	5	16		0	0	0	0
17:45	0	1	0	1	1	2	0	3	0	0	0	0	0	0	0	0	4	14		0	0	0	0
18:00	0	1	0	1	1	0	1	2	0	0	0	0	0	0	0	0	3	13		0	0	0	0
18:15	0	2	0	2	0	0	0	0	0	0	0	0	0	1	0	1	3	15		0	0	0	0
n/a																							
n/a																							
n/a																							
n/a																							
n/a																							
n/a																							
n/a																							
n/a																							
n/a																							
Total	0	20	1	21	2	41	2	45	1	2	0	3	2	2	0	4	73			0	0	0	0

Time Period Begins	Interurban Rd				Interurban Rd				Marigold Rd				Marigold Rd				Total Volume	P.D.L.	Conflict						
	NORTH Approach				SOUTH Approach				WEST Approach				EAST Approach												
	Left	Thru	Right	Total	Left	Thru	Right	Total	Left	Thru	Right	Total	Left	Thru	Right	Total	15-min	Hour	N	S	W	E	15 min	Hr	
7:30	0	5	0	5	0	5	0	5	1	0	1	2	0	0	0	0	12		+	0	0	0	0	6	
7:45	0	2	0	2	0	0	1	1	0	0	1	1	0	0	0	0	4		*	0	0	0	0	3	
8:00	0	3	1	4	0	0	0	0	0	0	0	0	1	0	0	1	5		*	0	0	0	0	5	
8:15	0	1	0	1	0	0	1	1	0	0	0	0	0	0	0	0	2	23	*	0	0	0	0	1	15
8:30	0	1	0	1	0	0	1	1	0	0	0	0	1	1	0	2	4	15		0	0	0	0	2	11
8:45	0	2	0	2	1	2	0	3	0	0	0	0	0	1	0	1	6	17		0	0	0	0	4	12
9:00	0	0	0	0	0	0	0	0	0	0	0	0	0	0	0	0	0	12		0	0	0	0	0	7
9:15	0	0	0	0	0	1	0	1	0	0	0	0	0	0	0	0	1	11		0	0	0	0	1	7
n/a																									
n/a																									
n/a																									
n/a																									
n/a																									
n/a																									
n/a																									
n/a																									
n/a																									
n/a																									
n/a																									
n/a																									
n/a																									
n/a																									

Total	0	14	1	15	1	8	3	12	1	0	2	3	2	2	0	4	34
Avg Hr	0	7	1	8	1	4	2	6	1	0	1	2	1	1	0	2	17

0	0	0	0	0
0	0	0	0	0

Peak hour of the intersection

Pk Hr	0	11	1	12	0	5	2	7	1	0	2	3	1	0	0	1	23*
15x4	0	20	4	20	0	20	4	20	4	0	4	8	4	0	0	4	48*
PHF	n/a	0.55	0.25	0.60	n/a	0.25	0.50	0.35	0.25	n/a	0.50	0.38	0.25	n/a	n/a	0.25	0.48

0	0	0	0	0
0	0	0	0	0
n/a	n/a	n/a	n/a	n/a

Peak hour of conflicting volumes for the intersection

Pk Hr	0	11	1	12	0	5	2	7	1	0	2	3	1	0	0	1	23*
15x4	0	20	4	20	0	20	4	20	4	0	4	8	4	0	0	4	48*
PHF	n/a	0.55	0.25	0.60	n/a	0.25	0.50	0.35	0.25	n/a	0.50	0.38	0.25	n/a	n/a	0.25	0.48

0	0	0	0	0
0	0	0	0	0
n/a	n/a	n/a	n/a	n/a

** Calculated peak hour occurs during the first or last hour of shift and therefore may be invalid. **

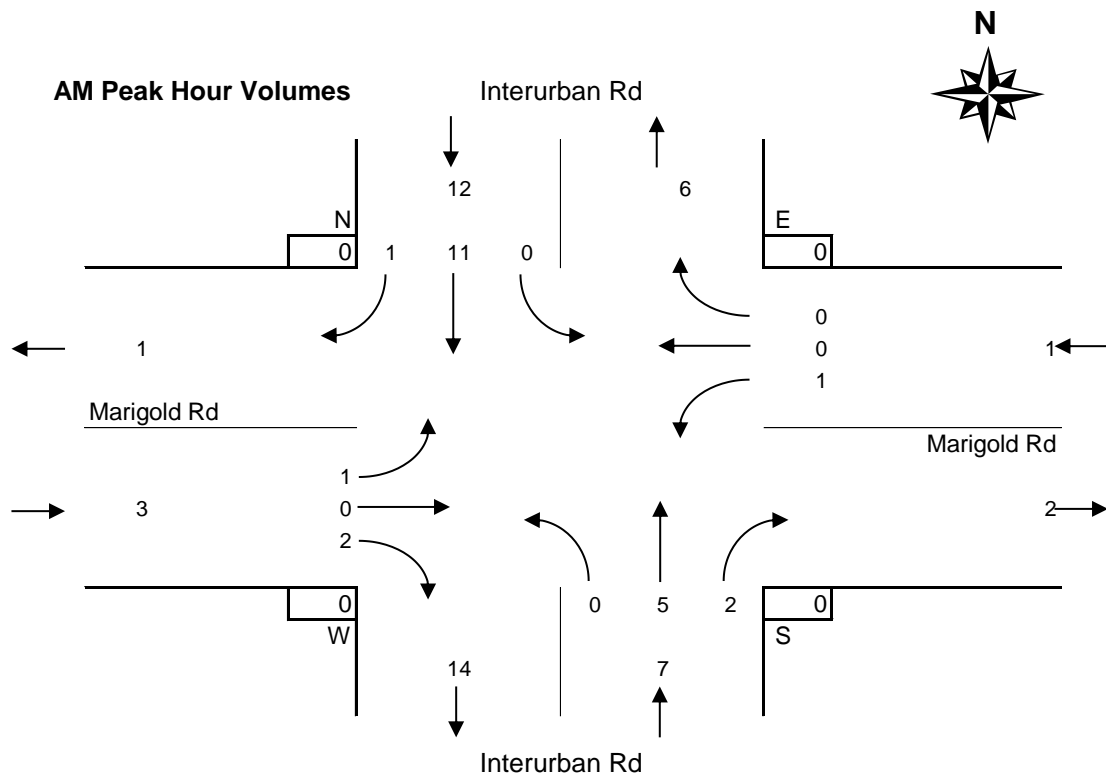

Time Period Begins	Interurban Rd				Interurban Rd				Marigold Rd				Marigold Rd				Total Volume		Days of Week	Conflict					
	NORTH Approach				SOUTH Approach				WEST Approach				EAST Approach				15-min	Hour		N	S	W	E	15 min	Hr
	Left	Thru	Right	Total	Left	Thru	Right	Total	Left	Thru	Right	Total	Left	Thru	Right	Total									
n/a																									
n/a																									
n/a																									
n/a																									
n/a																									
n/a																									
n/a																									
n/a																									
n/a																									
n/a																									
n/a																									
n/a																									
n/a																									
n/a																									
n/a																									
n/a																									
n/a																									

Total																							
Avg Hr																							

Peak hour of the intersection

Pk Hr																							
15x4																							
PHF																							

Peak hour of conflicting volumes for the intersection

Pk Hr																							
15x4																							
PHF																							

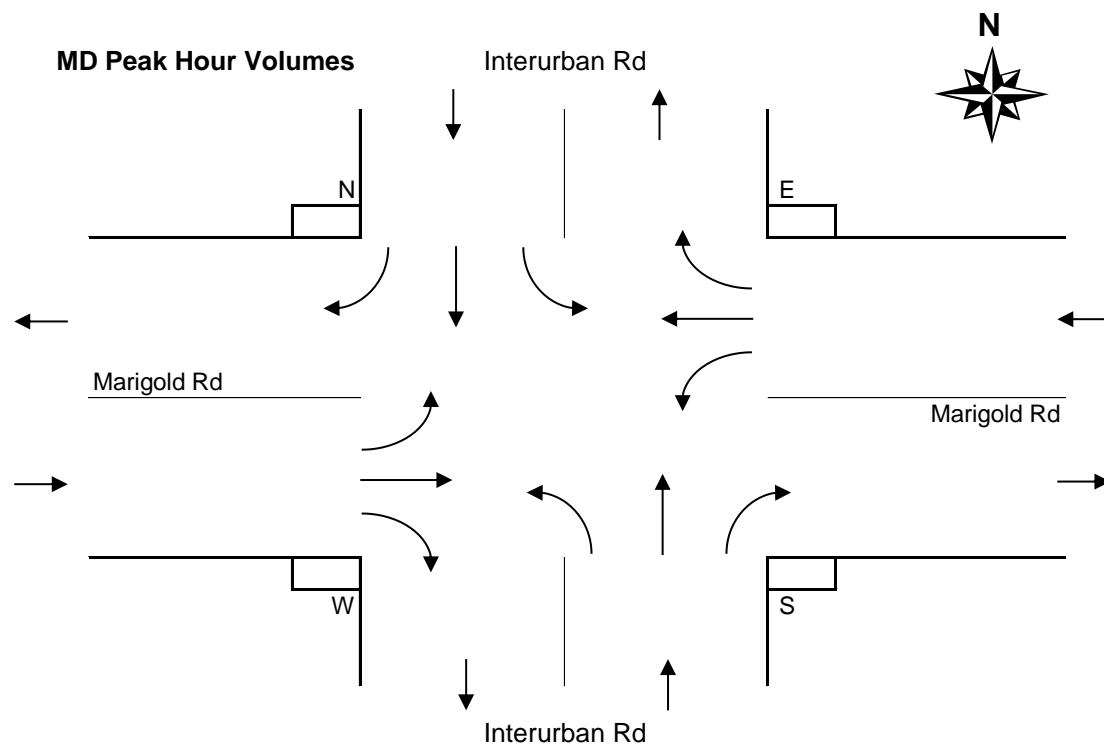

Time Period Begins	Interurban Rd				Interurban Rd				Marigold Rd				Marigold Rd				Total Volume		Speed	Conflict				
	NORTH Approach				SOUTH Approach				WEST Approach				EAST Approach				15-min	Hour		N	S	W	E	15 min
15:30	0	3	0	3	0	2	0	2	1	1	0	2	0	0	0	0	7		0	0	0	0	4	
15:45	0	4	0	4	0	6	0	6	0	1	0	1	0	1	0	1	12	+	0	0	0	0	7	
16:00	0	1	0	1	0	9	0	9	0	0	0	0	0	0	0	0	10	*	0	0	0	0	9	
16:15	0	3	0	3	0	5	0	5	0	0	0	0	1	0	0	1	9	38*	0	0	0	0	6	26
16:30	0	1	1	2	0	6	0	6	0	0	0	0	1	0	0	1	9	40*	0	0	0	0	7	29
16:45	0	2	0	2	0	4	0	4	0	0	0	0	0	0	0	0	6	34	0	0	0	0	4	26
17:00	0	1	0	1	0	3	0	3	0	0	0	0	0	0	0	0	4	28	0	0	0	0	3	20
17:15	0	1	0	1	0	0	0	0	0	0	0	0	0	0	0	0	1	20	0	0	0	0	1	15
17:30	0	0	0	0	0	4	1	5	0	0	0	0	0	0	0	0	5	16	0	0	0	0	5	13
17:45	0	1	0	1	1	2	0	3	0	0	0	0	0	0	0	0	4	14	0	0	0	0	2	11
18:00	0	1	0	1	1	0	1	2	0	0	0	0	0	0	0	0	3	13	0	0	0	0	2	10
18:15	0	2	0	2	0	0	0	0	0	0	0	0	0	1	0	1	3	15	0	0	0	0	3	12
n/a																								
n/a																								
n/a																								
n/a																								
n/a																								
n/a																								
n/a																								
n/a																								
n/a																								

Total	0	20	1	21	2	41	2	45	1	2	0	3	2	2	0	4	73	0	0	0	0	47
Avg Hr	0	7	0	7	1	14	1	15	0	1	0	1	1	1	0	1	24	0	0	0	0	

Peak hour of the intersection

Pk Hr	0	9	1	10	0	26	0	26	0	1	0	1	2	1	0	3	40*	0	0	0	0	29
15x4	0	16	4	16	0	36	0	36	0	4	0	4	4	4	0	4	48*	0	0	0	0	44
PHF	n/a	0.56	0.25	0.63	n/a	0.72	n/a	0.72	n/a	0.25	n/a	0.25	0.50	0.25	n/a	0.75	0.83	n/a	n/a	n/a	n/a	0.66

Peak hour of conflicting volumes for the intersection

Pk Hr	0	9	1	10	0	26	0	26	0	1	0	1	2	1	0	3	40*	0	0	0	0	29
15x4	0	16	4	16	0	36	0	36	0	4	0	4	4	4	0	4	48*	0	0	0	0	44
PHF	n/a	0.56	0.25	0.63	n/a	0.72	n/a	0.72	n/a	0.25	n/a	0.25	0.50	0.25	n/a	0.75	0.83	n/a	n/a	n/a	n/a	0.66

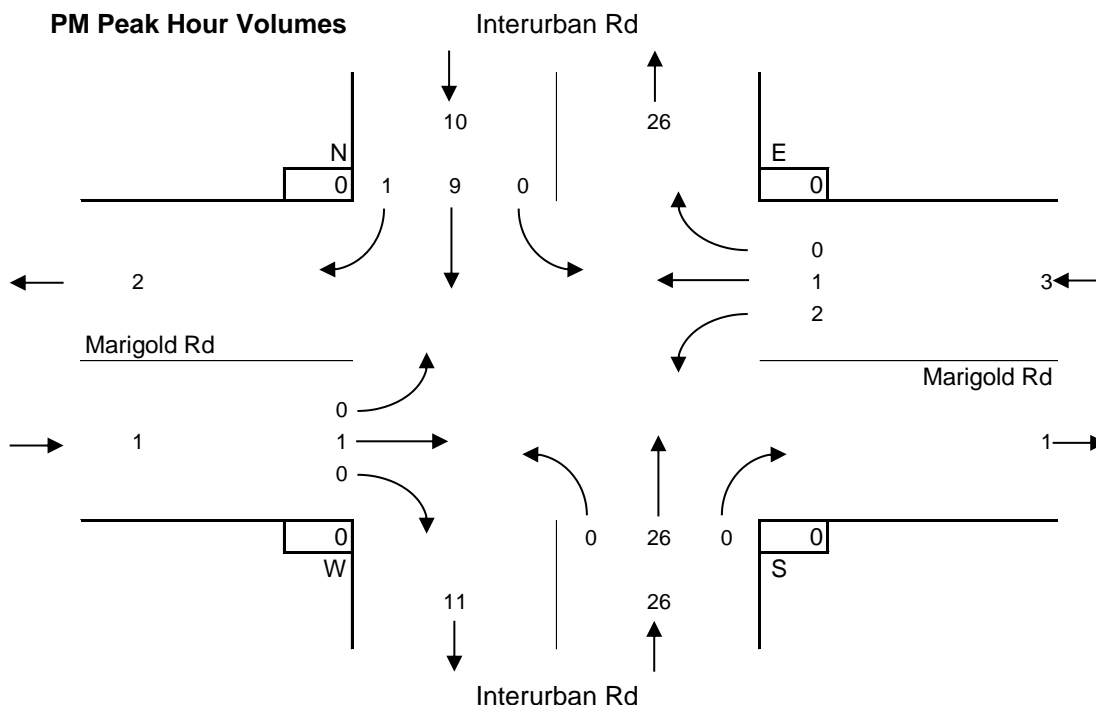

Entire Survey Period

5 Hours

	Interurban Rd				Interurban Rd				Marigold Rd				Marigold Rd				Total Volume				
	NORTH Approach				SOUTH Approach				WEST Approach				EAST Approach					N	S	W	E
	Left	Thru	Right	Total	Left	Thru	Right	Total	Left	Thru	Right	Total	Left	Thru	Right	Total					
Total	0	34	2	36	3	49	5	57	2	2	2	6	4	4	0	8	107	0	0	0	0
Avg Hr	0	7	0	7	1	10	1	11	0	0	0	1	1	1	0	2	21	0	0	0	0

AM Peak Period

2 Hours

	Interurban Rd				Interurban Rd				Marigold Rd				Marigold Rd				Total Volume				
	NORTH Approach				SOUTH Approach				WEST Approach				EAST Approach					N	S	W	E
	Left	Thru	Right	Total	Left	Thru	Right	Total	Left	Thru	Right	Total	Left	Thru	Right	Total					
Totals	0	14	1	15	1	8	3	12	1	0	2	3	2	2	0	4	34	0	0	0	0
Avg Hr	0	7	1	8	1	4	2	6	1	0	1	2	1	1	0	2	17	0	0	0	0

MD Peak Period

Hours

	Interurban Rd				Interurban Rd				Marigold Rd				Marigold Rd				Total Volume				
	NORTH Approach				SOUTH Approach				WEST Approach				EAST Approach					N	S	W	E
	Left	Thru	Right	Total	Left	Thru	Right	Total	Left	Thru	Right	Total	Left	Thru	Right	Total					
Totals																					
Total																					
Avg Hr																					

PM Peak Period

3 Hours

	Interurban Rd				Interurban Rd				Marigold Rd				Marigold Rd				Total Volume				
	NORTH Approach				SOUTH Approach				WEST Approach				EAST Approach					N	S	W	E
	Left	Thru	Right	Total	Left	Thru	Right	Total	Left	Thru	Right	Total	Left	Thru	Right	Total					
Totals	0	20	1	21	2	41	2	45	1	2	0	3	2	2	0	4	73	0	0	0	0
Avg Hr	0	7	0	7	1	14	1	15	0	1	0	1	1	1	0	1	24	0	0	0	0

