

Cordova Bay Road @ Fenn Avenue

Tuesday, October 17, 2017



The data presented here is for information purposes only and should not be considered authoritative for construction, geotechnical, engineering, navigational, legal, or other site-specific uses. The information shared is owned by the Transportation Division of the Engineering Department at the District of Saanich. Accuracy is not guaranteed.

DISTRICT OF SAANICH 2017 TRAFFIC COUNTS

Major Route: Cordova Bay Road
Minor Route: Fenn Avenue
Date: Tuesday, October 17, 2017
Filename: Cordova Bay@Fenn-Oct17-2017.xls

Station #: TIN001701
Intersection Type: 3-leg east approach
East/West Route: Fenn Avenue
Weather: Rain and wet

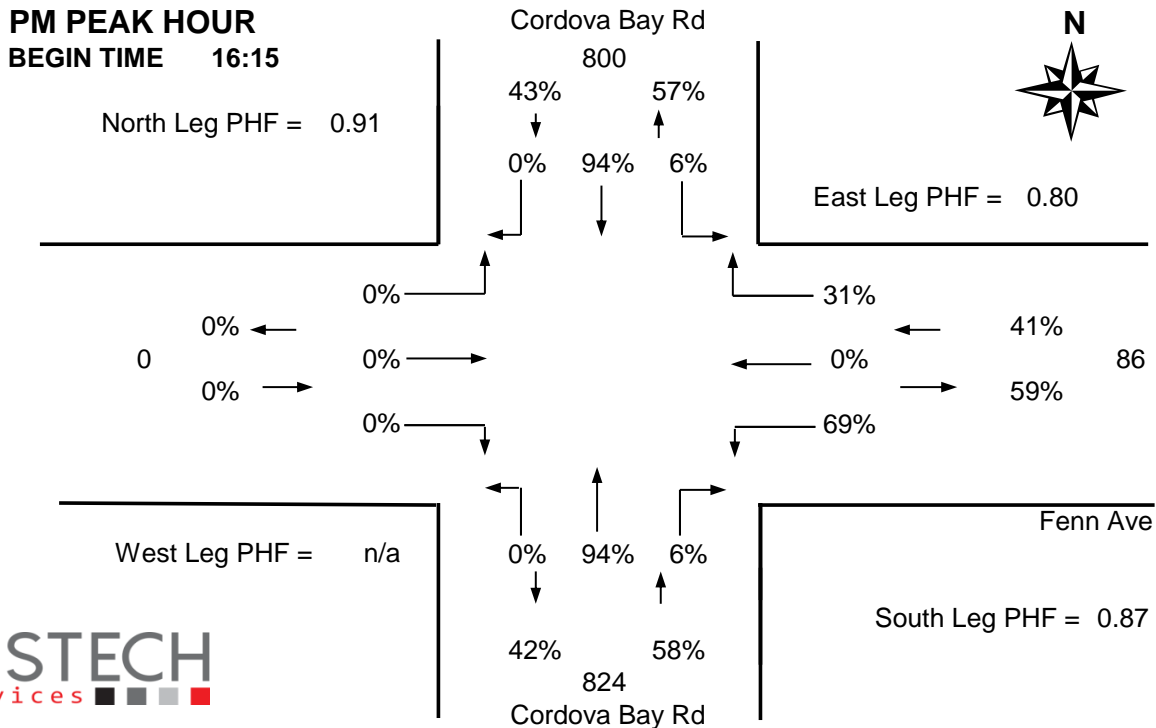
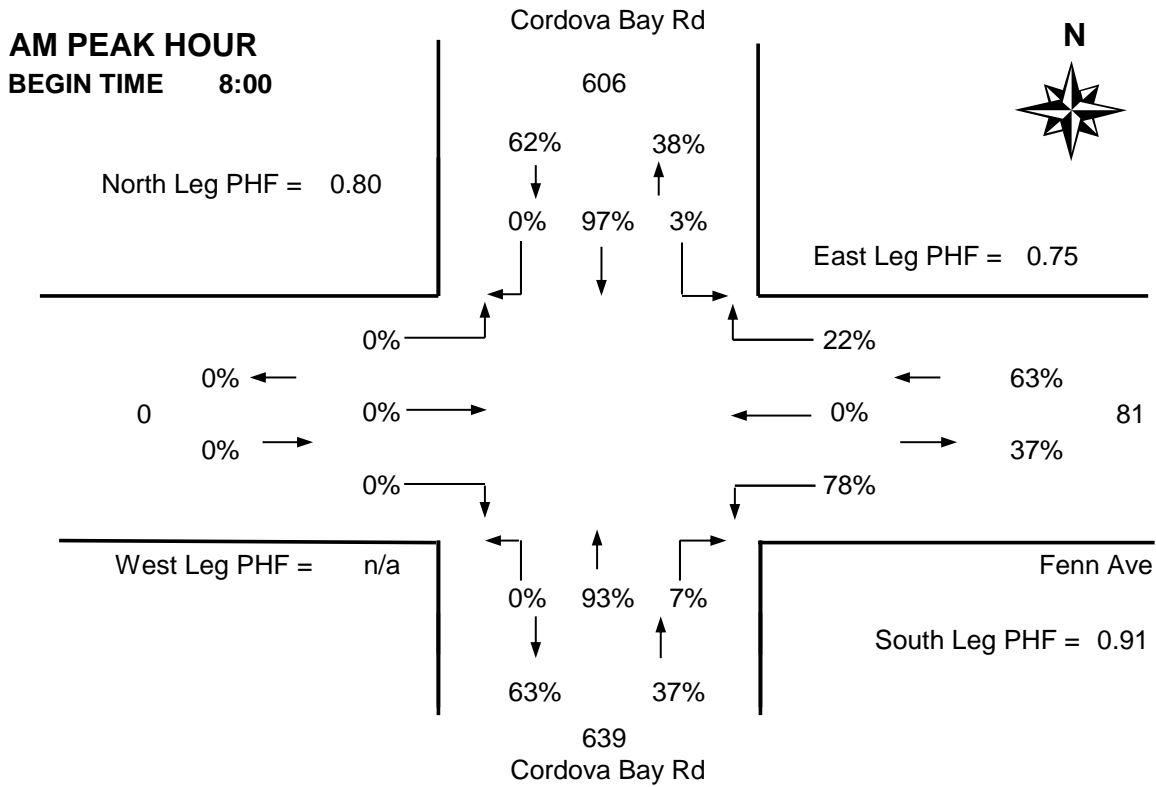

DISTRICT OF SAANICH 2017 TRAFFIC COUNTS

Major Route: Cordova Bay Road
Minor Route: Fenn Avenue
Date: Tuesday, October 17, 2017
Filename: Cordova Bay@Fenn-Oct17-2017.xls

Station #: TIN001701
Intersection Type: 3-leg east approach
East/West Route: Fenn Avenue
Weather: Rain and wet

Comments:

Vehicle Data

Time Period Starting	Cordova Bay Rd			Cordova Bay Rd			From West			Fenn Ave			15 Min Total	Hourly Total	Pedestrians			
	From North			From South			Left	Thru	Right	From East					N	S	W	E
	Left	Thru	Right	Left	Thru	Right				Left	Thru	Right						
7:30	3	47			52	2				9		0	113	-	0	0		0
7:45	1	84			52	4				4		3	148	-	0	0		0
8:00	7	110			55	2				2		2	178 *	-	0	0		0
8:15	0	75			45	4				12		5	141 *	580	0	0		0
8:30	3	106			62	3				13		3	190 +	657	13	0		1
8:45	3	72			57	8				13		1	154 *	663	5	0		0
9:00	2	64			34	3				5		0	108	593	0	0		0
9:15	1	54			54	2				9		3	123	575	0	0		0
Total	20	612	0	0	411	28	0	0	0	67	0	17	1155	-	18	0	0	1
Pk Hr	13	363	0	0	219	17	0	0	0	40	0	11	663 *	-	18	0	0	1
Pk Hr Factor	0.46	0.83	n/a	n/a	0.88	0.53	n/a	n/a	n/a	0.77	n/a	0.55	0.87	* = Peak hour + = Peak 15 minutes				
Factor	0.80			0.91			n/a			0.75								
15:30	8	69			82	5				5		6	175	-	4	0		0
15:45	2	74			113	8				6		8	211	-	2	0		0
16:00	2	80			96	9				5		7	199	-	1	0		3
16:15	5	78			107	6				5		4	205 *	790	1	0		1
16:30	10	84			108	7				7		4	220 *	835	4	0		2
16:45	2	77			132	6				5		2	224 +	848	0	0		0
17:00	3	82			101	12				7		1	206 *	855	3	0		2
17:15	5	77			96	7				7		2	194	844	0	0		0
Total	37	621	0	0	835	60	0	0	0	47	0	34	1634	-	15	0	0	8
Pk Hr	20	321	0	0	448	31	0	0	0	24	0	11	855 *	-	8	0	0	5
Pk Hr Factor	0.50	0.96	n/a	n/a	0.85	0.65	n/a	n/a	n/a	0.86	n/a	0.69	0.95					
Factor	0.91			0.87			n/a			0.80								

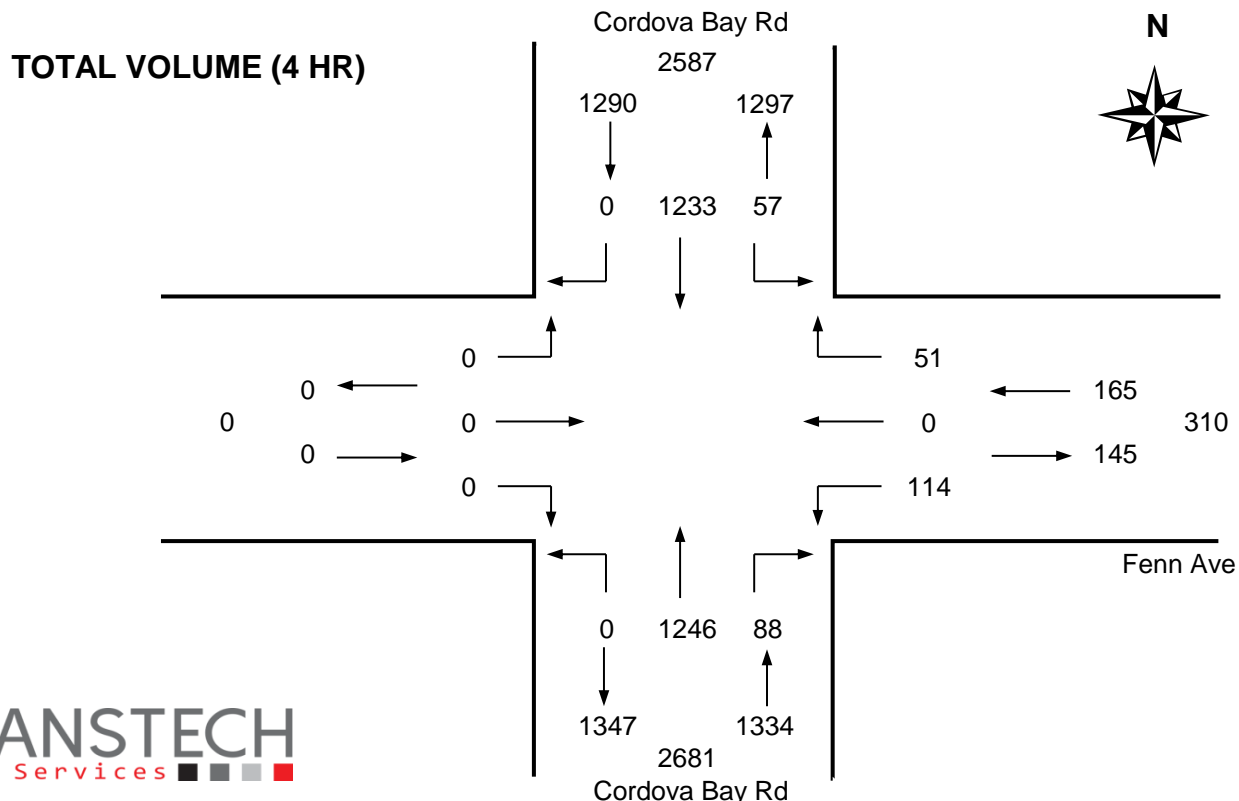

DISTRICT OF SAANICH 2017 TRAFFIC COUNTS

Major Route: Cordova Bay Road
Minor Route: Fenn Avenue
Date: Tuesday, October 17, 2017
Filename: Cordova Bay@Fenn-Oct17-2017.xls

Station #: TIN001701
Intersection Type: 3-leg east approach
East/West Route: Fenn Avenue
Weather: Rain and wet

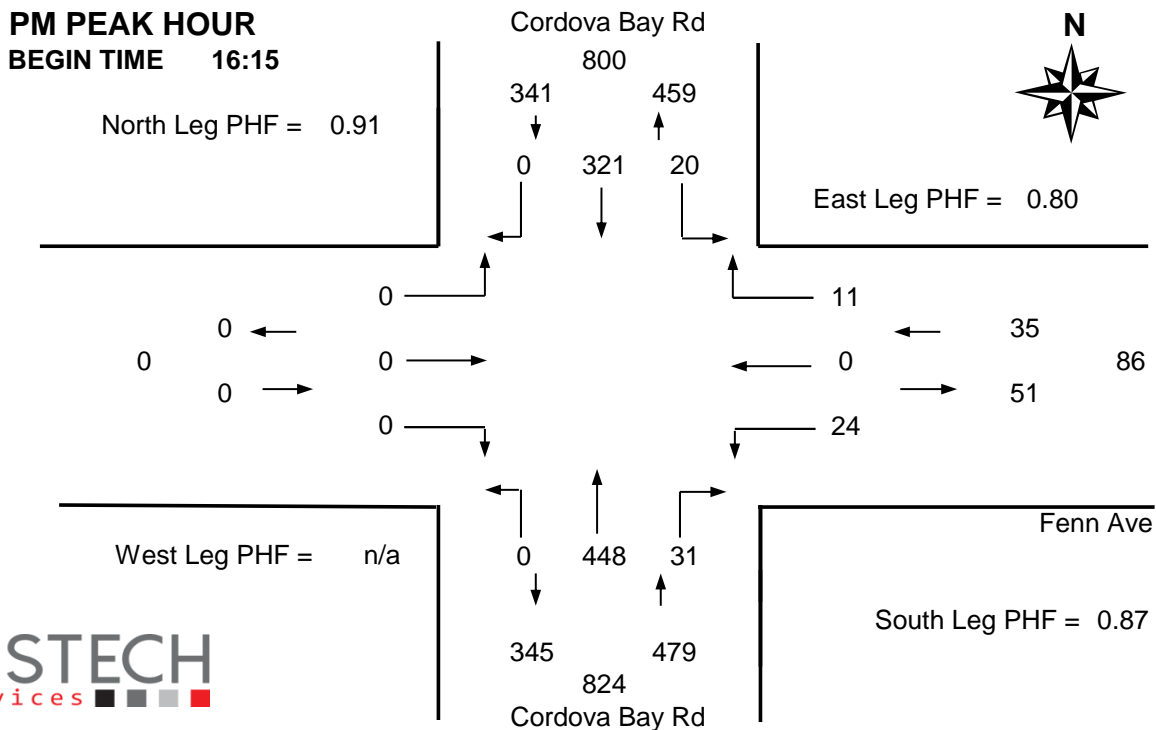
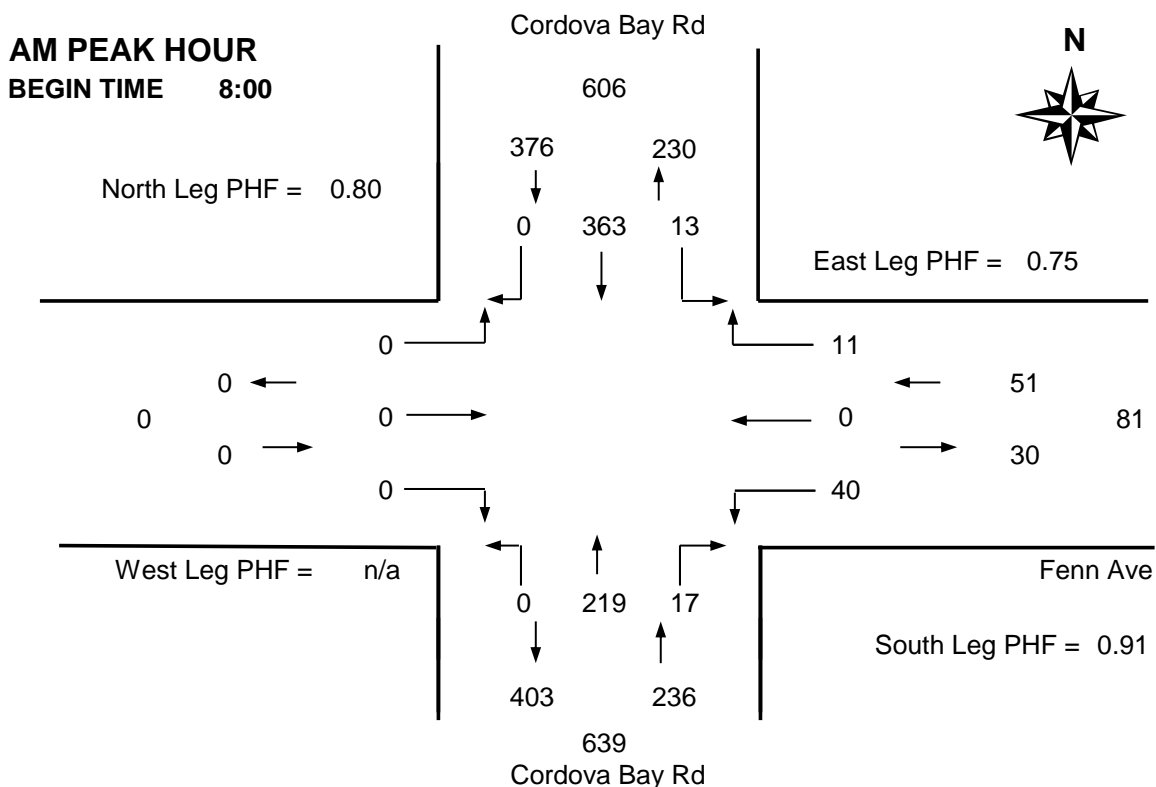

DISTRICT OF SAANICH 2017 TRAFFIC COUNTS

Major Route: Cordova Bay Road
Minor Route: Fenn Avenue
Date: Tuesday, October 17, 2017
Filename: Cordova Bay@Fenn-Oct17-2017.xls

Station #: TIN001701
Intersection Type: 3-leg east approach
East/West Route: Fenn Avenue
Weather: Rain and wet

Comments:

Bicycle Data

Time Period Starting	Cordova Bay Rd			Cordova Bay Rd			Fenn Ave			15 Min Total	Hourly Total			
	From North			From South			From West					From East		
	Left	Thru	Right	Left	Thru	Right	Left	Thru	Right			Left	Thru	Right
7:30	0	0			0	0				0		0	0 *	-
7:45	0	0			0	0				0		0	0 *	-
8:00	0	0			3	0				0		0	3 +	-
8:15	0	0			1	0				0		0	1 *	4
8:30	0	0			0	0				0		0	0	4
8:45	0	0			0	0				0		0	0	4
9:00	0	0			0	0				0		0	0	1
9:15	0	0			1	0				0		0	1	1
Total	0	0	0	0	5	0	0	0	0	0	0	0	5	-
Pk Hr	0	0	0	0	4	0	0	0	0	0	0	0	4 *	-
15x4	0	0	0	0	12	0	0	0	0	0	0	0	12 +	-

15:30	0	0			0	0				0		0	0	-
15:45	0	0			1	0				0		0	1	-
16:00	0	0			0	0				0		0	0	-
16:15	0	0			1	0				0		0	1	2
16:30	0	0			0	0				0		0	0 *	2
16:45	0	0			1	0				0		0	1 *	2
17:00	0	0			1	0				0		0	1 *	3
17:15	0	1			1	0				0		0	2 +	4
Total	0	1	0	0	5	0	0	0	0	0	0	0	6	-
Pk Hr	0	1	0	0	3	0	0	0	0	0	0	0	4 *	-
15x4	0	4	0	0	4	0	0	0	0	0	0	0	8 +	-

4 Hr	0	1	0	0	10	0	0	0	0	0	0	0	0	11	22
------	---	---	---	---	----	---	---	---	---	---	---	---	---	----	----

PEAK HOUR SUMMARY

