

Carey Road @ Glanford Avenue

Wednesday, April 03, 2019



The data presented here is for information purposes only and should not be considered authoritative for construction, geotechnical, engineering, navigational, legal, or other site-specific uses. The information shared is owned by the Transportation Division of the Engineering Department at the District of Saanich. Accuracy is not guaranteed.

Major Route: Carey Road
Minor Route: Glanford Avenue
Municipality: Saanich
Filename: Carey Rd @ Glanford Ave-Apr 3, 2019.xlsx
Location #: TIN001191
Count ID: 2019003
Date: April 3, 2019
Day-of-week: Wednesday

East/West Route: Glanford Avenue
Intersection Type: 4-leg
Signalized?: Yes
Weather: Overcast and dry

Vehicle Classifications: Vehicles and Peds
 Bikes

This data is for Vehicles and Peds

Shift	Start	End	Duration
AM	7:30	9:30	2.00
MD			
PM	15:30	18:30	3.00
Total	7:30	18:30	5.00

Notes: 24-hour clock used for reporting (15-minute increments)
 North Approach - southbound vehicles approaching intersection from the north
 15x4 - 15 min volume (from maximum 15 minute period of movement/approach in peak hour period [*]) x 4
 Pedestrians - N indicates pedestrians crossing north approach (east/west)

Comments:

Time Period Begins	Carey Rd				Carey Rd				Glanford Ave				Glanford Ave				Total Volume		Ped Vol	Crosswalks				Conflict	
	NORTH Approach				SOUTH Approach				WEST Approach				EAST Approach				15-min	Hour		N	S	W	E	15 min	Hr
	Left	Thru	Right	Total	Left	Thru	Right	Total	Left	Thru	Right	Total	Left	Thru	Right	Total									
7:30	0	83	2	85	12	109	1	122	3	1	53	57	8	2	1	11	275		0	1	4	3	172		
7:45	0	91	7	98	17	104	2	123	1	1	74	76	8	2	2	12	309		2	3	0	2	198		
8:00	0	105	7	112	27	99	0	126	2	4	55	61	4	3	5	12	311	*	5	3	3	7	202		
8:15	0	112	9	121	29	138	0	167	2	4	57	63	5	6	2	13	364	1259+	0	2	1	1	216	788	
8:30	0	116	4	120	21	132	3	156	1	0	52	53	6	1	3	10	339	1323*	0	2	1	0	199	815	
8:45	1	117	5	123	7	119	0	126	2	1	64	67	1	1	0	2	318	1332*	0	0	3	1	195	812	
9:00	0	103	9	112	27	89	4	120	0	2	51	53	4	0	1	5	290	1311	0	0	0	1	196	806	
9:15	1	74	8	83	12	90	3	105	3	2	41	46	2	0	0	2	236	1183	0	1	3	1	139	729	
n/a																									
n/a																									
n/a																									
n/a																									
n/a																									
n/a																									
n/a																									
n/a																									
n/a																									
n/a																									
n/a																									
n/a																									

Total	2	801	51	854	152	880	13	1045	14	15	447	476	38	15	14	67	2442								7	12	15	16	1504
Avg Hr	1	401	26	427	76	440	7	523	7	8	224	238	19	8	7	34	1221								4	6	8	8	

Peak hour of the intersection

Pk Hr	1	450	25	476	84	488	3	575	7	9	228	244	16	11	10	37	1332*								5	7	8	9	812
15x4	4	468	36	492	116	552	12	668	8	16	256	268	24	24	20	52	1456+								20	12	12	28	916
PHF	0.25	0.96	0.69	0.97	0.72	0.88	0.25	0.86	0.88	0.56	0.89	0.91	0.67	0.46	0.50	0.71	0.91								0.25	0.58	0.67	0.32	0.89

Peak hour of conflicting volumes for the intersection

Pk Hr	0	424	27	451	94	473	5	572	6	9	238	253	23	12	12	47	1323*								7	10	5	10	815
15x4	0	464	36	484	116	552	12	668	8	16	296	304	32	24	20	52	1456+								20	12	12	28	960
PHF	n/a	0.91	0.75	0.93	0.81	0.86	0.42	0.86	0.75	0.56	0.80	0.83	0.72	0.50	0.60	0.90	0.91								0.35	0.83	0.42	0.36	0.85

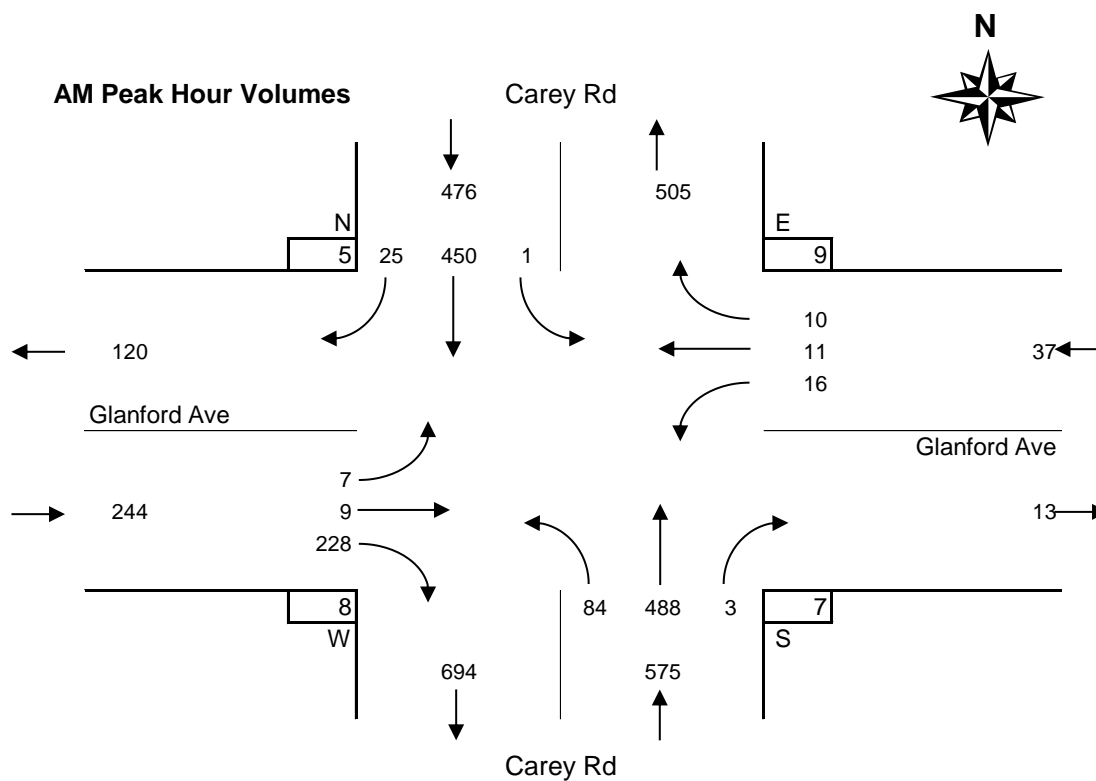

Time Period Begins	Carey Rd				Carey Rd				Glanford Ave				Glanford Ave				Total Volume		Mod	Crosswalks				Conflict			
	NORTH Approach				SOUTH Approach				WEST Approach				EAST Approach				15-min	Hour		N	S	W	E	15 min	Hr		
	Left	Thru	Right	Total	Left	Thru	Right	Total	Left	Thru	Right	Total	Left	Thru	Right	Total											
n/a																											
n/a																											
n/a																											
n/a																											
n/a																											
n/a																											
n/a																											
n/a																											
n/a																											
n/a																											
n/a																											
n/a																											
n/a																											
n/a																											
n/a																											
n/a																											
n/a																											
n/a																											
n/a																											
n/a																											

Total																												
Avg Hr																												

Peak hour of the intersection

Pk Hr																												
15x4																												
PHF																												

Peak hour of conflicting volumes for the intersection

Pk Hr																												
15x4																												
PHF																												

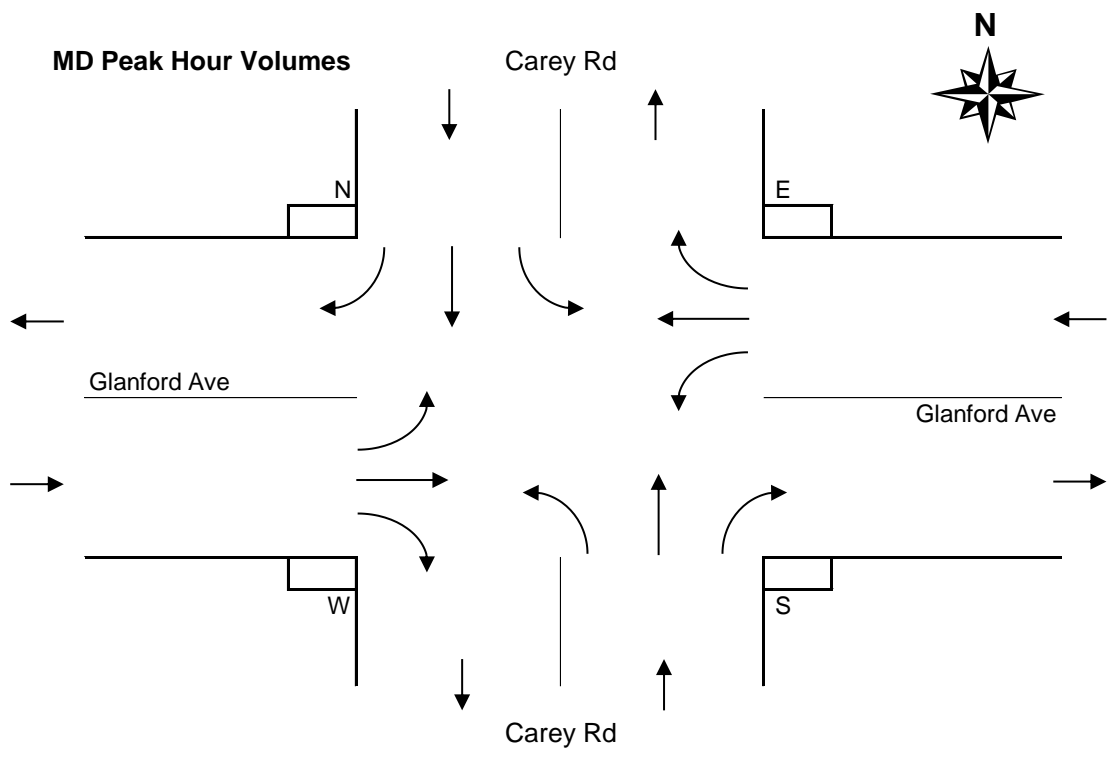

Time Period Begins	Carey Rd NORTH Approach				Carey Rd SOUTH Approach				Glanford Ave WEST Approach				Glanford Ave EAST Approach				Total Volume		V/D	Crosswalks				Conflict	
	Left	Thru	Right	Total	Left	Thru	Right	Total	Left	Thru	Right	Total	Left	Thru	Right	Total	15-min	Hour		N	S	W	E	15 min	Hr
15:30	1	146	20	167	65	155	5	225	3	1	27	31	4	1	0	5	428		1	1	5	1	263		
15:45	2	107	23	132	79	153	6	238	2	0	30	32	3	1	3	7	409		3	7	6	4	242		
16:00	2	97	24	123	86	167	9	262	6	4	36	46	2	4	3	9	440	*	0	3	2	1	249		
16:15	3	114	15	132	104	161	3	268	1	0	42	43	1	1	1	3	446	1723*	1	1	4	3	276	1030	
16:30	2	76	22	100	120	170	5	295	2	5	24	31	3	0	3	6	432	1727*	0	5	1	3	250	1017	
16:45	0	99	19	118	110	180	10	300	3	2	39	44	2	1	2	5	467	1785+	0	4	0	4	271	1046	
17:00	2	96	14	112	103	158	4	265	4	2	29	35	4	1	0	5	417	1762	1	1	2	3	248	1045	
17:15	0	114	31	145	91	147	8	246	1	7	39	47	4	2	1	7	445	1761	3	1	1	4	286	1055	
17:30	3	124	18	145	81	111	3	195	1	1	32	34	3	2	1	6	380	1709	2	4	0	2	259	1064	
17:45	2	89	17	108	55	120	5	180	1	0	33	34	4	1	0	5	327	1569	0	1	2	0	198	991	
18:00	2	93	5	100	59	102	5	166	1	1	22	24	2	1	2	5	295	1447	2	3	2	0	182	925	
18:15	4	110	8	122	41	106	4	151	0	1	15	16	5	0	0	5	294	1296	0	3	0	2	180	819	
n/a																									
n/a																									
n/a																									
n/a																									
n/a																									
n/a																									
n/a																									
n/a																									
n/a																									
n/a																									
n/a																									

Total	23	1265	216	1504	994	1730	67	2791	25	24	368	417	37	15	16	68	4780							
Avg Hr	8	422	72	501	331	577	22	930	8	8	123	139	12	5	5	23	1593							

13	34	25	27	2904
4	11	8	9	

Peak hour of the intersection

Pk Hr	7	386	80	473	420	678	27	1125	12	11	141	164	8	6	9	23	1785*							
15x4	12	456	96	528	480	720	40	1200	24	20	168	184	12	16	12	36	1868+							
PHF	0.58	0.85	0.83	0.90	0.88	0.94	0.68	0.94	0.50	0.55	0.84	0.89	0.67	0.38	0.75	0.64	0.96							

1	13	7	11	1046
4	20	16	16	1232
0.25	0.65	0.44	0.69	0.85

Peak hour of conflicting volumes for the intersection

Pk Hr	5	433	82	520	385	596	25	1006	9	12	139	160	13	6	4	23	1709*							
15x4	12	496	124	580	440	720	40	1200	16	28	156	188	16	8	8	28	1868+							
PHF	0.42	0.87	0.66	0.90	0.88	0.83	0.63	0.84	0.56	0.43	0.89	0.85	0.81	0.75	0.50	0.82	0.91							

6	10	3	13	1064
12	16	8	16	1260
0.50	0.63	0.38	0.81	0.84

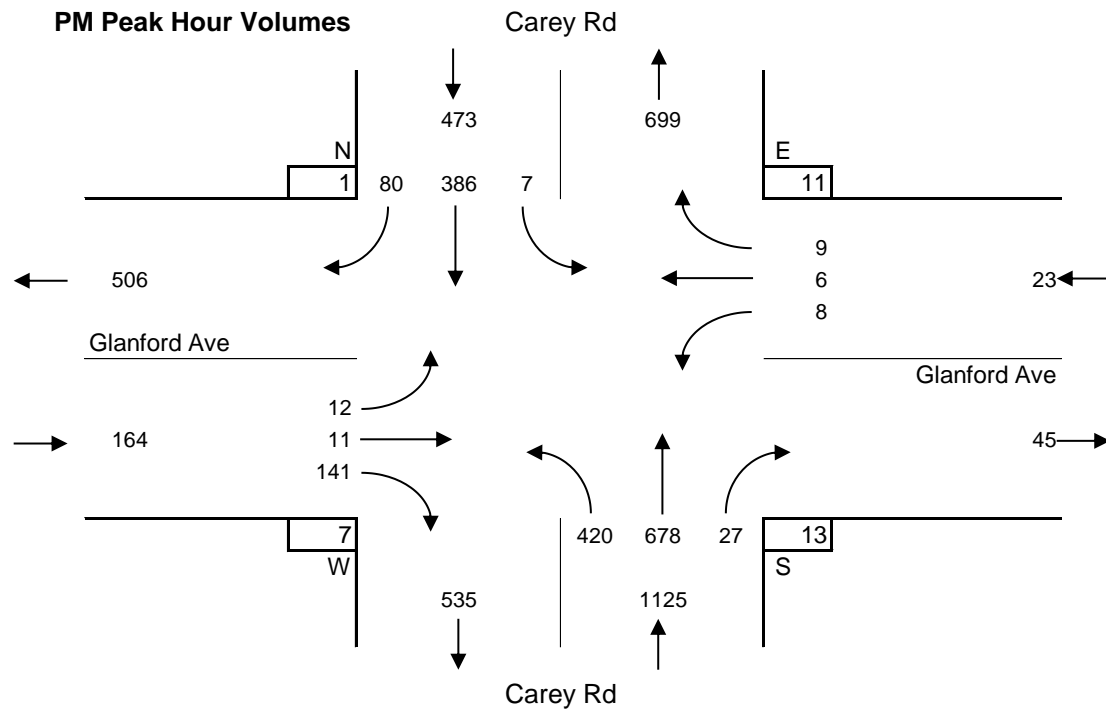

Entire Survey Period

5 Hours

	Carey Rd				Carey Rd				Glanford Ave				Glanford Ave				Total Volume	Crosswalks			
	NORTH Approach				SOUTH Approach				WEST Approach				EAST Approach					N	S	W	E
	Left	Thru	Right	Total	Left	Thru	Right	Total	Left	Thru	Right	Total	Left	Thru	Right	Total					
Total	25	2066	267	2358	1146	2610	80	3836	39	39	815	893	75	30	30	135	7222	20	46	40	43
Avg Hr	5	413	53	472	229	522	16	767	8	8	163	179	15	6	6	27	1444	4	9	8	9

AM Peak Period

2 Hours

	Carey Rd				Carey Rd				Glanford Ave				Glanford Ave				Total Volume	Crosswalks			
	NORTH Approach				SOUTH Approach				WEST Approach				EAST Approach					N	S	W	E
	Left	Thru	Right	Total	Left	Thru	Right	Total	Left	Thru	Right	Total	Left	Thru	Right	Total					
Totals	2	801	51	854	152	880	13	1045	14	15	447	476	38	15	14	67	2442	7	12	15	16
Avg Hr	1	401	26	427	76	440	7	523	7	8	224	238	19	8	7	34	1221	4	6	8	8

MD Peak Period

Hours

	Carey Rd				Carey Rd				Glanford Ave				Glanford Ave				Total Volume	Crosswalks			
	NORTH Approach				SOUTH Approach				WEST Approach				EAST Approach					N	S	W	E
	Left	Thru	Right	Total	Left	Thru	Right	Total	Left	Thru	Right	Total	Left	Thru	Right	Total					
Total																					
Avg Hr																					

PM Peak Period

3 Hours

	Carey Rd				Carey Rd				Glanford Ave				Glanford Ave				Total Volume	Crosswalks			
	NORTH Approach				SOUTH Approach				WEST Approach				EAST Approach					N	S	W	E
	Left	Thru	Right	Total	Left	Thru	Right	Total	Left	Thru	Right	Total	Left	Thru	Right	Total					
Total	23	1265	216	1504	994	1730	67	2791	25	24	368	417	37	15	16	68	4780	13	34	25	27
Avg Hr	8	422	72	501	331	577	22	930	8	8	123	139	12	5	5	23	1593	4	11	8	9

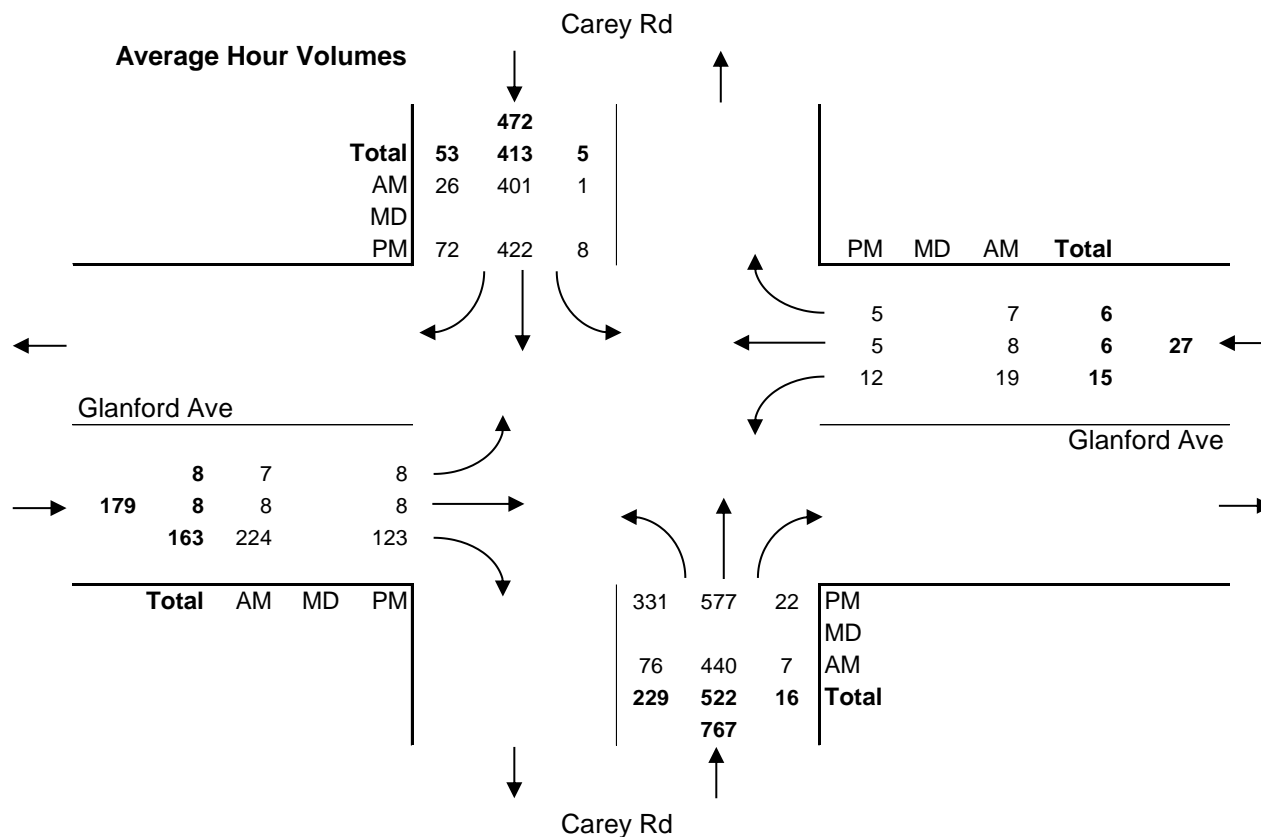

Major Route: Carey Road
Minor Route: Glanford Avenue
Municipality: Saanich
Filename: Carey Rd @ Glanford Ave-Apr 3, 2019.xlsx
Location #: TIN001191
Count ID: 2019003
Date: April 3, 2019
Day-of-week: Wednesday

East/West Route: Glanford Avenue
Intersection Type: 4-leg
Signalized?: Yes
Weather: Overcast and dry

Vehicle Classifications: Vehicles and Peds
 Bikes

This data is for Bikes

Shift	Start	End	Duration
AM	7:30	9:30	2.00
MD			
PM	15:30	18:30	3.00
Total	7:30	18:30	5.00

Notes: 24-hour clock used for reporting (15-minute increments)
 North Approach - southbound vehicles approaching intersection from the north
 15x4 - 15 min volume (from maximum 15 minute period of movement/approach in peak hour period [*]) x 4
 Pedestrians - N indicates pedestrians crossing north approach (east/west)

Comments:

Survey Data
Bikes

Carey Road @ Glanford Avenue
Wednesday, April 3, 2019

Time Period Begins	Carey Rd NORTH Approach				Carey Rd SOUTH Approach				Glanford Ave WEST Approach				Glanford Ave EAST Approach				Total Volume		Peak Period	N	S	W	E
	Left	Thru	Right	Total	Left	Thru	Right	Total	Left	Thru	Right	Total	Left	Thru	Right	Total	15-min	Hour					
7:30	0	4	0	4	0	1	0	1	0	0	3	3	0	0	0	0	8	*	0	0	0	0	
7:45	0	2	0	2	0	1	0	1	0	0	5	5	0	0	0	0	8	*	0	0	0	0	
8:00	0	3	0	3	0	0	0	0	0	0	5	5	1	0	0	1	9	+	0	0	0	0	
8:15	0	0	0	0	1	1	0	2	0	0	2	2	1	0	0	1	5	30*	0	0	0	0	
8:30	0	3	0	3	0	2	0	2	0	0	3	3	0	0	0	0	8	30	0	0	0	0	
8:45	0	0	0	0	0	1	0	1	0	0	1	1	0	0	0	0	2	24	0	0	0	0	
9:00	0	1	0	1	0	0	0	0	0	0	1	1	0	0	0	0	2	17	0	0	0	0	
9:15	0	3	0	3	0	0	0	0	0	0	1	1	0	0	0	0	4	16	0	0	0	0	
n/a																							
n/a																							
n/a																							
n/a																							
n/a																							
n/a																							
n/a																							
n/a																							
n/a																							
n/a																							
n/a																							
Total	0	16	0	16	1	6	0	7	0	0	21	21	2	0	0	2	46		0	0	0	0	

n/a																						
n/a																						
n/a																						
n/a																						
n/a																						
n/a																						
n/a																						
n/a																						
n/a																						
n/a																						
n/a																						
n/a																						
n/a																						
n/a																						
n/a																						
Total																						

15:30	0	1	0	1	2	1	0	3	0	0	0	0	0	0	0	0	4		0	0	0	0
15:45	0	0	0	0	0	0	0	0	0	0	0	0	0	0	0	0	0		0	0	0	0
16:00	0	0	0	0	2	0	0	2	0	0	0	0	0	0	0	0	2		0	0	0	0
16:15	0	1	0	1	1	2	0	3	0	0	0	0	0	0	0	0	4	10*	0	0	0	0
16:30	0	0	0	0	2	3	0	5	0	0	1	1	0	0	0	0	6	12*	0	0	0	0
16:45	0	1	0	1	6	4	0	10	0	0	0	0	0	0	0	0	11	23+	0	0	0	0
17:00	0	0	0	0	2	3	0	5	0	0	1	1	0	0	0	0	6	27*	0	0	0	0
17:15	0	0	0	0	1	0	1	2	0	0	0	0	0	0	0	0	2	25	0	0	0	0
17:30	0	0	0	0	1	0	0	1	0	0	2	2	0	0	0	0	3	22	0	0	0	0
17:45	0	0	0	0	1	2	0	3	0	0	0	0	0	0	0	0	3	14	0	0	0	0
18:00	0	4	0	4	1	0	0	1	0	0	0	0	0	0	0	0	5	13	0	0	0	0
18:15	0	1	0	1	0	0	0	0	0	0	0	0	0	0	0	0	1	12	0	0	0	0
n/a																						
n/a																						
n/a																						
n/a																						
n/a																						
n/a																						
n/a																						
n/a																						
Total	0	8	0	8	19	15	1	35	0	0	4	4	0	0	0	0	47		0	0	0	0

Time Period Begins	Carey Rd NORTH Approach				Carey Rd SOUTH Approach				Glanford Ave WEST Approach				Glanford Ave EAST Approach				Total Volume		Day of Week	Conflict				
	Left	Thru	Right	Total	Left	Thru	Right	Total	Left	Thru	Right	Total	Left	Thru	Right	Total	15-min	Hour		N	S	W	E	15 min
n/a																								
n/a																								
n/a																								
n/a																								
n/a																								
n/a																								
n/a																								
n/a																								
n/a																								
n/a																								
n/a																								
n/a																								
n/a																								
n/a																								
n/a																								
n/a																								

Total																								
Avg Hr																								

Peak hour of the intersection

Pk Hr																								
15x4																								
PHF																								

Peak hour of conflicting volumes for the intersection

Pk Hr																								
15x4																								
PHF																								

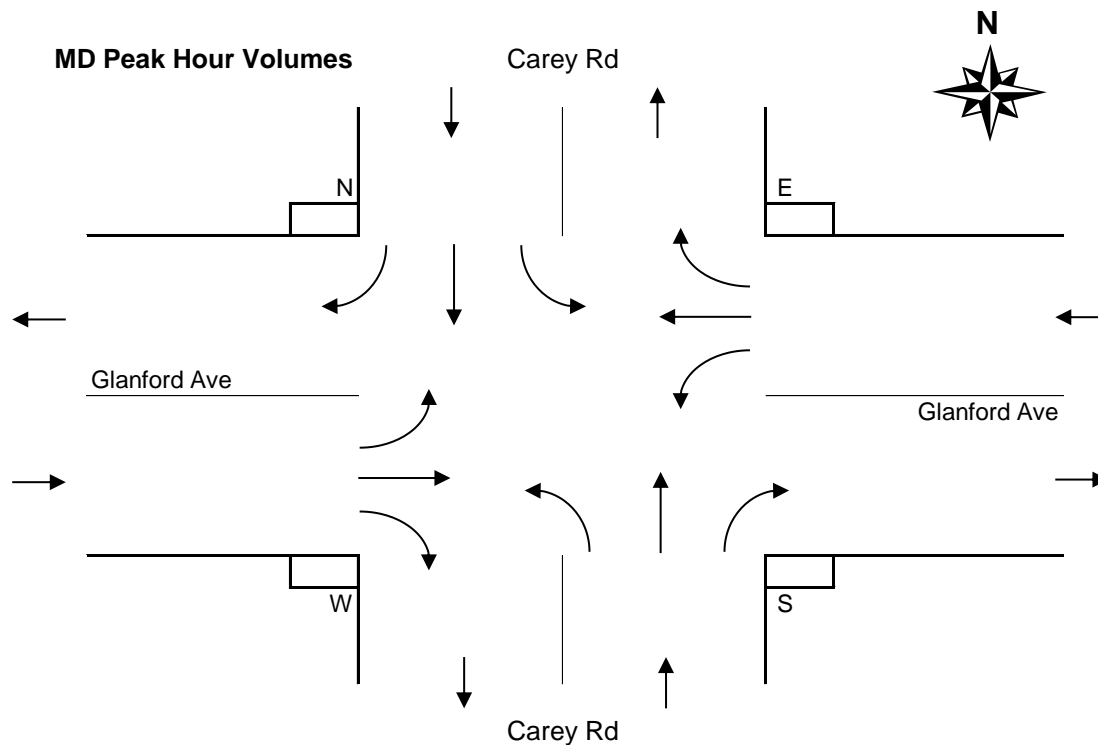

PM Peak Period
Bikes

Carey Road @ Glanford Avenue
Wednesday, April 3, 2019

Time Period Begins	Carey Rd NORTH Approach				Carey Rd SOUTH Approach				Glanford Ave WEST Approach				Glanford Ave EAST Approach				Total Volume		% Sat	Conflict				
	Left	Thru	Right	Total	Left	Thru	Right	Total	Left	Thru	Right	Total	Left	Thru	Right	Total	15-min	Hour		N	S	W	E	15 min
15:30	0	1	0	1	2	1	0	3	0	0	0	0	0	0	0	0	4		0	0	0	0	3	
15:45	0	0	0	0	0	0	0	0	0	0	0	0	0	0	0	0	0		0	0	0	0	0	
16:00	0	0	0	0	2	0	0	2	0	0	0	0	0	0	0	0	2		0	0	0	0	2	
16:15	0	1	0	1	1	2	0	3	0	0	0	0	0	0	0	0	4	10*	0	0	0	0	2	7
16:30	0	0	0	0	2	3	0	5	0	0	1	1	0	0	0	0	6	12*	0	0	0	0	4	8
16:45	0	1	0	1	6	4	0	10	0	0	0	0	0	0	0	0	11	23+	0	0	0	0	7	15
17:00	0	0	0	0	2	3	0	5	0	0	1	1	0	0	0	0	6	27*	0	0	0	0	4	17
17:15	0	0	0	0	1	0	1	2	0	0	0	0	0	0	0	0	2	25	0	0	0	0	1	16
17:30	0	0	0	0	1	0	0	1	0	0	2	2	0	0	0	0	3	22	0	0	0	0	3	15
17:45	0	0	0	0	1	2	0	3	0	0	0	0	0	0	0	0	3	14	0	0	0	0	2	10
18:00	0	4	0	4	1	0	0	1	0	0	0	0	0	0	0	0	5	13	0	0	0	0	5	11
18:15	0	1	0	1	0	0	0	0	0	0	0	0	0	0	0	0	1	12	0	0	0	0	1	11
n/a																								
n/a																								
n/a																								
n/a																								
n/a																								
n/a																								
n/a																								
n/a																								
n/a																								
n/a																								
n/a																								
n/a																								

Total	0	8	0	8	19	15	1	35	0	0	4	4	0	0	0	0	47								31
Avg Hr	0	3	0	3	6	5	0	12	0	0	1	1	0	0	0	0	16								

Peak hour of the intersection

Pk Hr	0	2	0	2	11	12	0	23	0	0	2	2	0	0	0	0	27*							15
15x4	0	4	0	4	24	16	0	40	0	0	4	4	0	0	0	0	44*							32
PHF	n/a	0.50	n/a	0.50	0.46	0.75	n/a	0.58	n/a	n/a	0.50	0.50	n/a	n/a	n/a	n/a	0.61							0.47

Peak hour of conflicting volumes for the intersection

Pk Hr	0	2	0	2	11	12	0	23	0	0	2	2	0	0	0	0	27*							15
15x4	0	4	0	4	24	16	0	40	0	0	4	4	0	0	0	0	44*							32
PHF	n/a	0.50	n/a	0.50	0.46	0.75	n/a	0.58	n/a	n/a	0.50	0.50	n/a	n/a	n/a	n/a	0.61							0.47

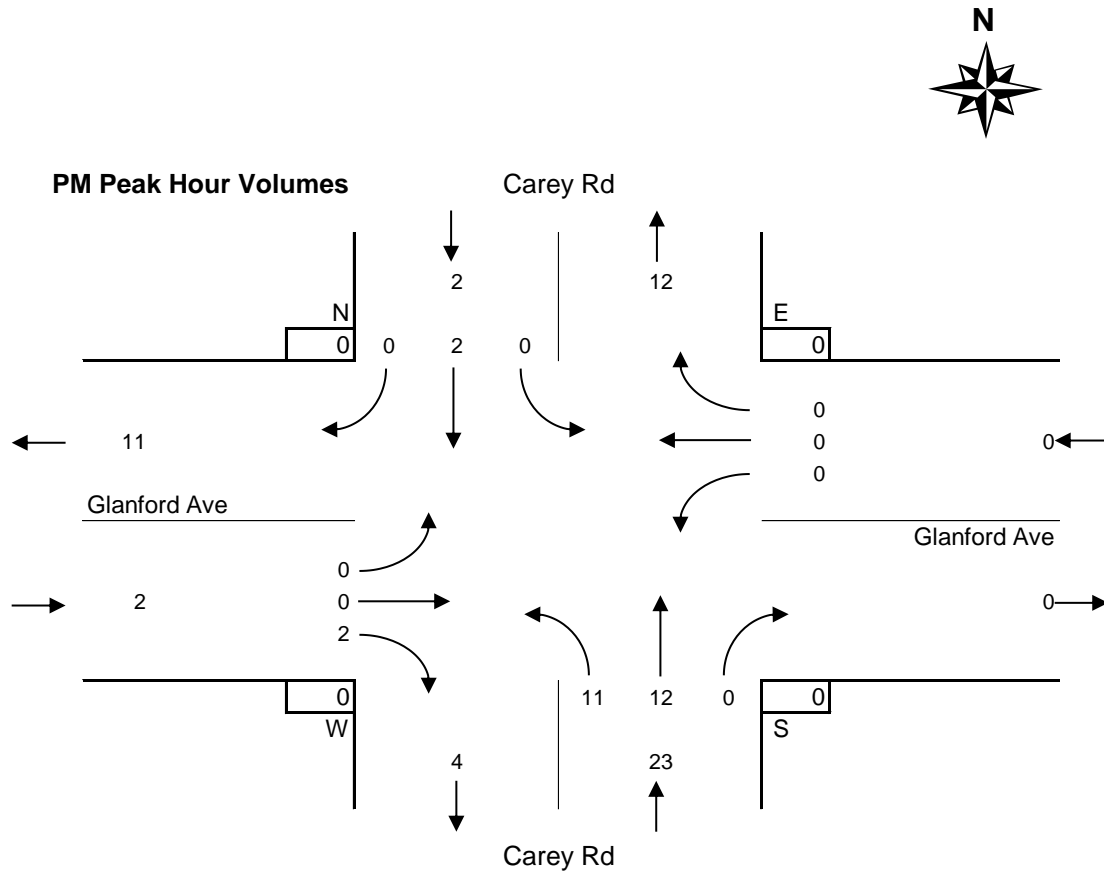

Entire Survey Period

5 Hours

	Carey Rd				Carey Rd				Glanford Ave				Glanford Ave				Total Volume				
	NORTH Approach				SOUTH Approach				WEST Approach				EAST Approach					N	S	W	E
	Left	Thru	Right	Total	Left	Thru	Right	Total	Left	Thru	Right	Total	Left	Thru	Right	Total					
Total	0	24	0	24	20	21	1	42	0	0	25	25	2	0	0	2	93	0	0	0	0
Avg Hr	0	5	0	5	4	4	0	8	0	0	5	5	0	0	0	0	19	0	0	0	0

AM Peak Period

2 Hours

	Carey Rd				Carey Rd				Glanford Ave				Glanford Ave				Total Volume				
	NORTH Approach				SOUTH Approach				WEST Approach				EAST Approach					N	S	W	E
	Left	Thru	Right	Total	Left	Thru	Right	Total	Left	Thru	Right	Total	Left	Thru	Right	Total					
Totals	0	16	0	16	1	6	0	7	0	0	21	21	2	0	0	2	46	0	0	0	0
Avg Hr	0	8	0	8	1	3	0	4	0	0	11	11	1	0	0	1	23	0	0	0	0

MD Peak Period

Hours

	Carey Rd				Carey Rd				Glanford Ave				Glanford Ave				Total Volume				
	NORTH Approach				SOUTH Approach				WEST Approach				EAST Approach					N	S	W	E
	Left	Thru	Right	Total	Left	Thru	Right	Total	Left	Thru	Right	Total	Left	Thru	Right	Total					
Total																					
Avg Hr																					

PM Peak Period

3 Hours

	Carey Rd				Carey Rd				Glanford Ave				Glanford Ave				Total Volume				
	NORTH Approach				SOUTH Approach				WEST Approach				EAST Approach					N	S	W	E
	Left	Thru	Right	Total	Left	Thru	Right	Total	Left	Thru	Right	Total	Left	Thru	Right	Total					
Totals	0	8	0	8	19	15	1	35	0	0	4	4	0	0	0	0	47	0	0	0	0
Avg Hr	0	3	0	3	6	5	0	12	0	0	1	1	0	0	0	0	16	0	0	0	0

