

Ash Road @ Majestic Drive

Thursday, March 08, 2018



The data presented here is for information purposes only and should not be considered authoritative for construction, geotechnical, engineering, navigational, legal, or other site-specific uses. The information shared is owned by the Transportation Division of the Engineering Department at the District of Saanich. Accuracy is not guaranteed.

DISTRICT OF SAANICH 2018 TRAFFIC COUNTS

Major Route: Ash Road
Minor Route: Majestic Drive
Date: Thursday, March 8, 2018
Filename: Ash@Majestic-Mar8-2018.xls

Station #: TIN000570
Intersection Type: 3-leg south approach
East/West Route: Ash Road
Weather: Cloudy and damp

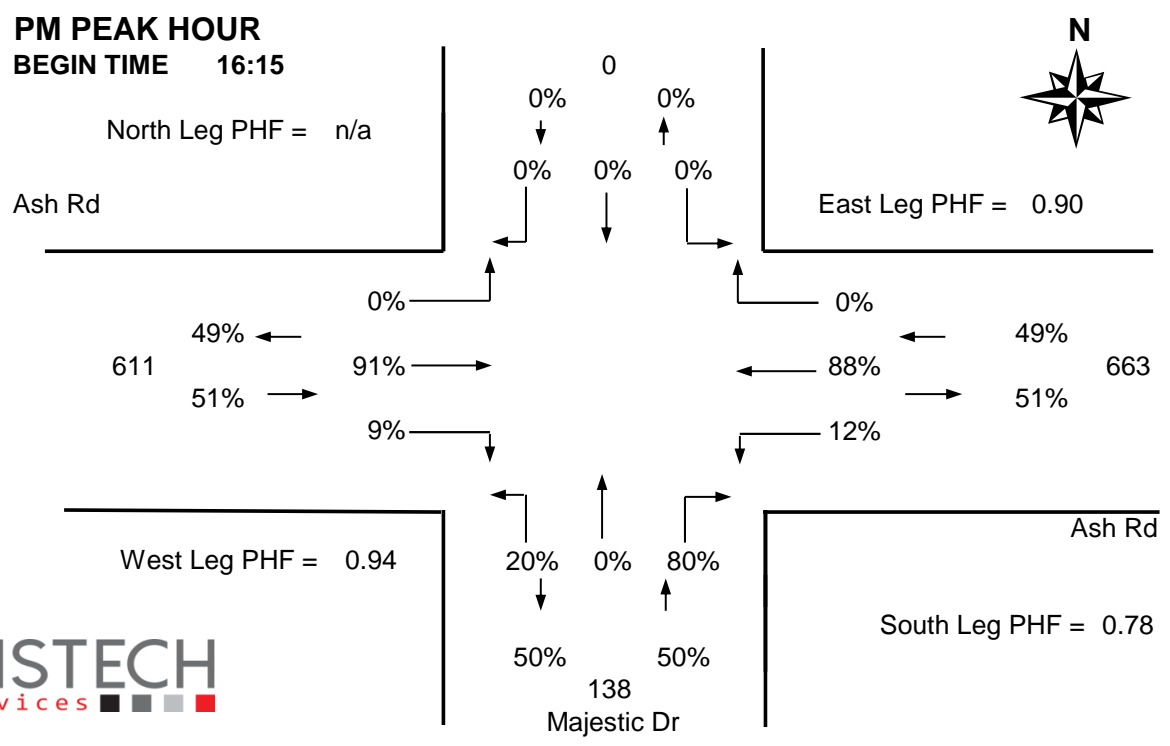
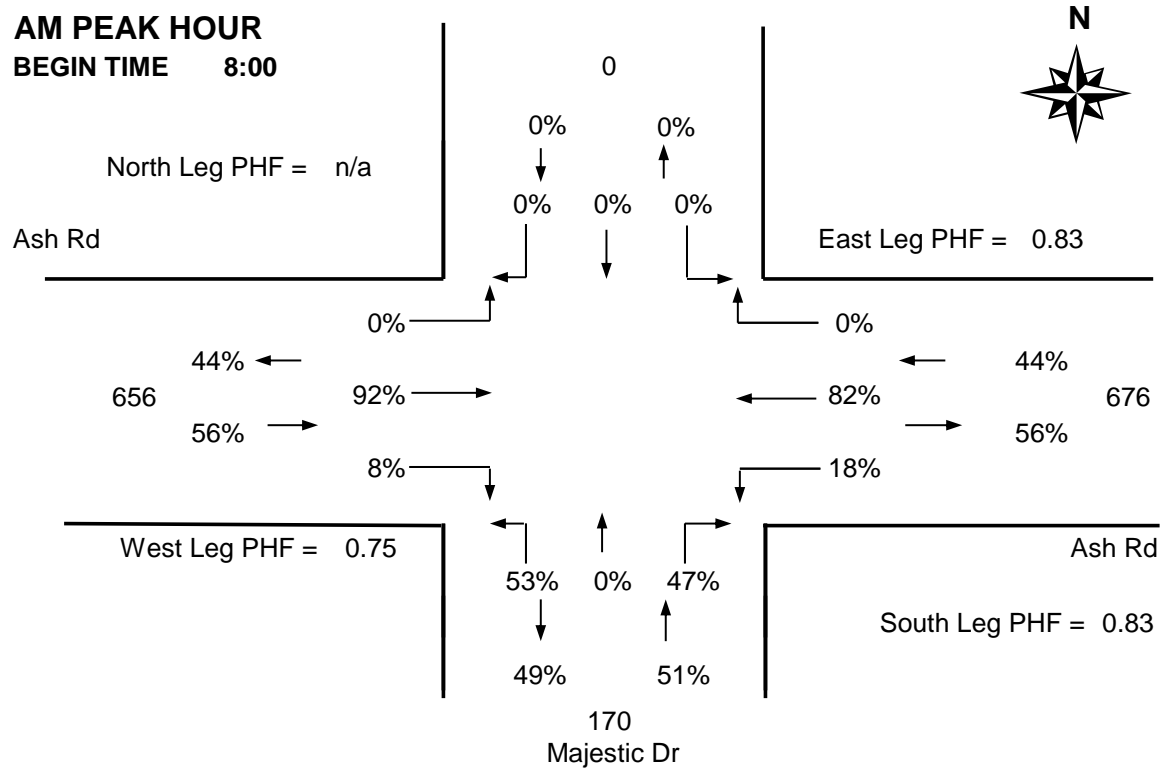

DISTRICT OF SAANICH 2018 TRAFFIC COUNTS

Major Route: Ash Road
Minor Route: Majestic Drive
Date: Thursday, March 8, 2018
Filename: Ash@Majestic-Mar8-2018.xls

Station #: TIN000570
Intersection Type: 3-leg south approach
East/West Route: Ash Road
Weather: Cloudy and damp

Comments:

Vehicle Data

Time Period Starting	Majestic Dr			Ash Rd			Ash Rd			15 Min Total	Hourly Total	Pedestrians						
	From North			From South			From West					From East			N	S	W	E
	Left	Thru	Right	Left	Thru	Right	Left	Thru	Right			Left	Thru	Right				
7:30				7		2		30	5	6	45		95	-		3	0	0
7:45				11		2		76	6	12	43		150	-		2	0	0
8:00				12		5		116	3	11	54		201 *	-		0	0	0
8:15				9		11		113	9	14	52		208 +	654		4	0	0
8:30				13		13		56	10	19	71		182 *	741		1	0	0
8:45				12		11		52	7	11	67		160 *	751		2	0	0
9:00				3		7		44	5	4	40		103	653		2	0	0
9:15				3		2		59	6	7	37		114	559		0	0	1
Total	0	0	0	70	0	53	0	546	51	84	409	0	1213	-	0	14	0	1
Pk Hr	0	0	0	46	0	40	0	337	29	55	244	0	751 *	-	0	7	0	0
Pk Hr Factor	n/a	n/a	n/a	0.88	n/a	0.77	n/a	0.73	0.73	0.72	0.86	n/a	0.90	* = Peak hour + = Peak 15 minutes				
n/a				0.83			0.75			0.83								
15:30				10		11		50	10	3	89		173	-		1	0	0
15:45				3		8		56	4	7	74		152	-		1	1	0
16:00				6		6		50	6	11	78		157	-		0	1	1
16:15				2		16		70	7	8	66		169 *	651		2	0	0
16:30				3		7		65	7	9	82		173 *	651		5	0	0
16:45				5		17		71	7	7	73		180 *	679		2	0	0
17:00				4		15		74	8	16	67		184 +	706		7	1	0
17:15				6		5		64	8	4	63		150	687		3	0	0
Total	0	0	0	39	0	85	0	500	57	65	592	0	1338	-	0	21	3	1
Pk Hr	0	0	0	14	0	55	0	280	29	40	288	0	706 *	-	0	16	1	0
Pk Hr Factor	n/a	n/a	n/a	0.70	n/a	0.81	n/a	0.95	0.91	0.63	0.88	n/a	0.96					
n/a				0.78			0.94			0.90								

TOTAL VOLUME (4 HR)

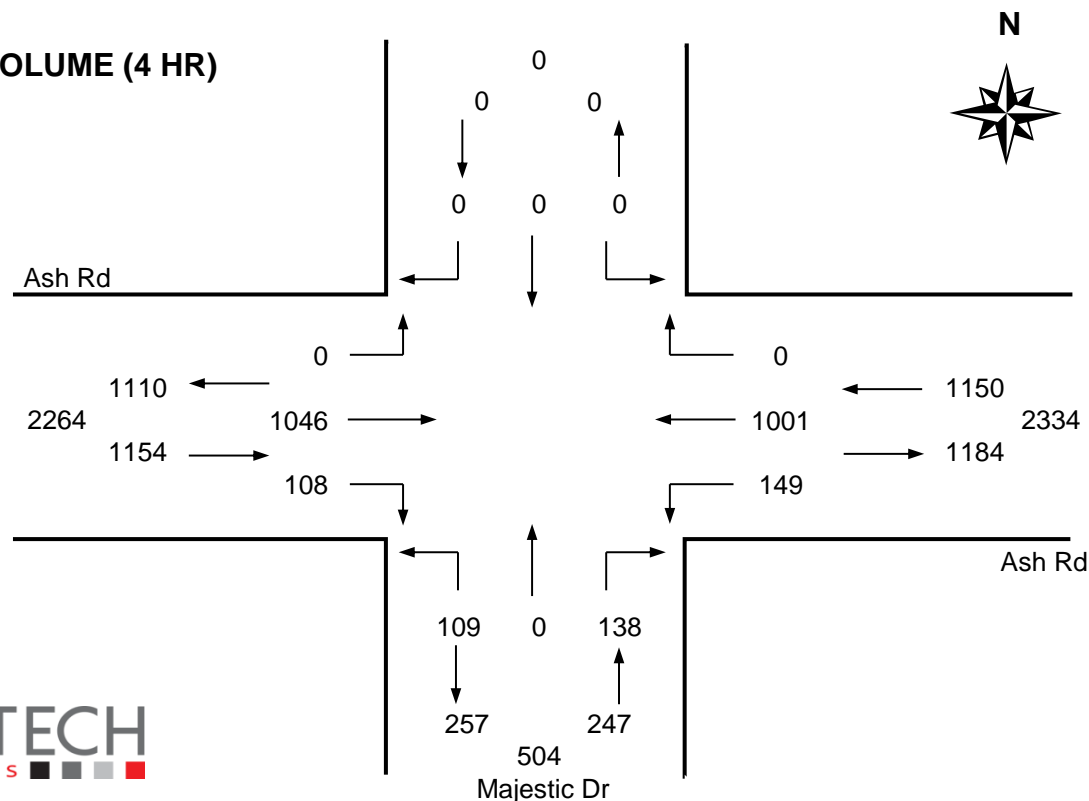

DISTRICT OF SAANICH 2018 TRAFFIC COUNTS

Major Route: Ash Road
Minor Route: Majestic Drive
Date: Thursday, March 8, 2018
Filename: Ash@Majestic-Mar8-2018.xls

Station #: TIN000570
Intersection Type: 3-leg south approach
East/West Route: Ash Road
Weather: Cloudy and damp

AM PEAK HOUR BEGIN TIME 8:00

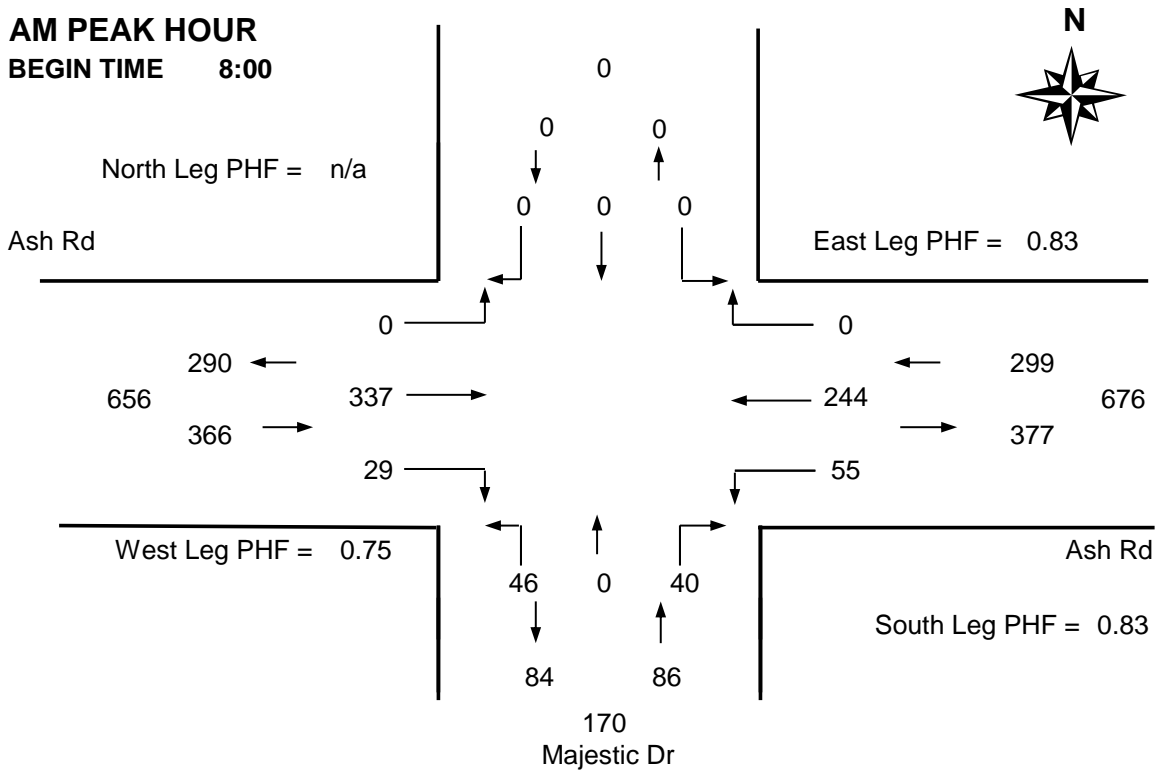

PM PEAK HOUR BEGIN TIME 16:15

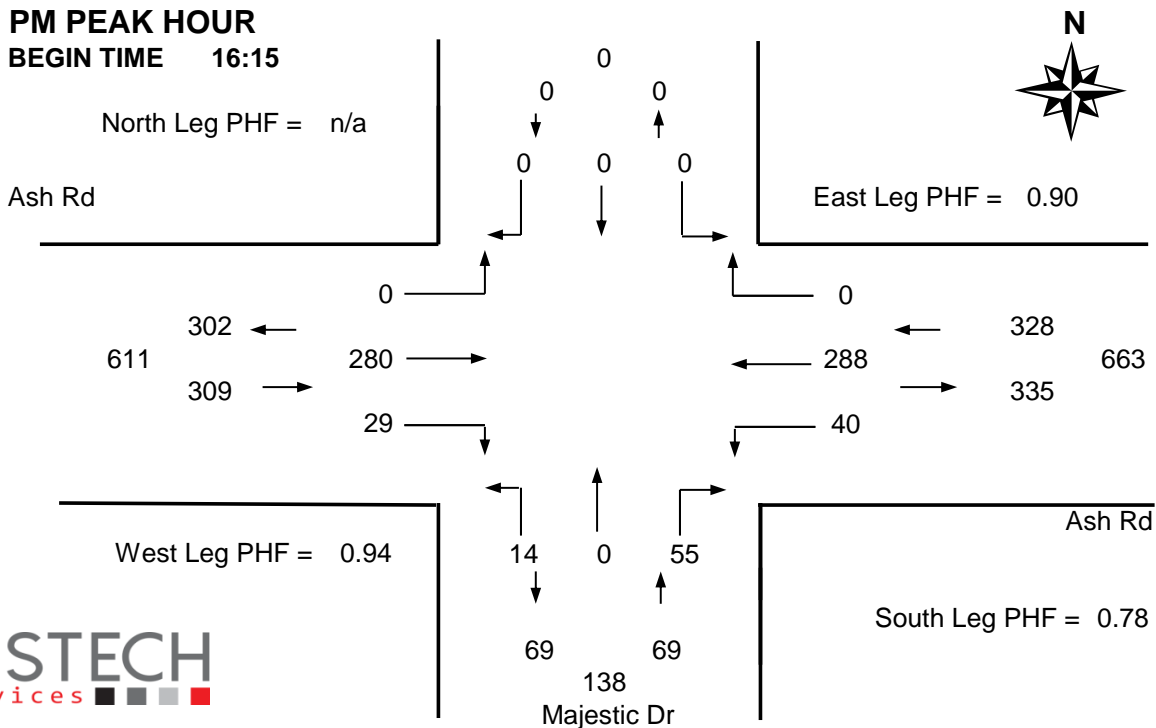

DISTRICT OF SAANICH 2018 TRAFFIC COUNTS

Major Route: Ash Road
Minor Route: Majestic Drive
Date: Thursday, March 8, 2018
Filename: Ash@Majestic-Mar8-2018.xls

Station #: TIN000570
Intersection Type: 3-leg south approach
East/West Route: Ash Road
Weather: Cloudy and damp

Comments:

Bicycle Data

Time Period Starting	Majestic Dr			Ash Rd			Ash Rd			15 Min Total	Hourly Total			
	From North			From South			From West					From East		
	Left	Thru	Right	Left	Thru	Right	Left	Thru	Right			Left	Thru	Right
7:30				0		0		0	0	0	1		1 *	-
7:45				0		0		0	0	0	1		1 *	-
8:00				0		0		1	0	0	0		1 *	-
8:15				0		0		0	1	0	1		2 +	5
8:30				0		0		0	0	0	1		1	5
8:45				0		0		0	0	0	0		0	4
9:00				0		0		0	0	0	0		0	3
9:15				0		0		0	0	0	0		0	1
Total	0	0	0	0	0	0	0	1	1	0	4	0	6	-
Pk Hr	0	0	0	0	0	0	0	1	1	0	3	0	5 *	-
15x4	0	0	0	0	0	0	0	4	4	0	4	0	8 +	-

15:30				0		1		0	0	0	0		1	-
15:45				0		0		0	1	0	1		2	-
16:00				0		0		0	1	0	0		1	-
16:15				0		0		0	0	0	0		0	4
16:30				0		0		1	0	0	0		1 *	4
16:45				0		0		0	1	0	0		1 *	3
17:00				1		1		0	0	0	3		5 +	7
17:15				0		0		0	0	0	2		2 *	9
Total	0	0	0	1	0	2	0	1	3	0	6	0	13	-
Pk Hr	0	0	0	1	0	1	0	1	1	0	5	0	9 *	-
15x4	0	0	0	4	0	4	0	4	4	0	12	0	20 +	-

4 Hr	0	0	0	1	0	2	0	2	4	0	10	0	19	38
------	---	---	---	---	---	---	---	---	---	---	----	---	----	----

PEAK HOUR SUMMARY

