

Admirals Road @ Cowper Street

Tuesday, February 21, 2017



The data presented here is for information purposes only and should not be considered authoritative for construction, geotechnical, engineering, navigational, legal, or other site-specific uses. The information shared is owned by the Transportation Division of the Engineering Department at the District of Saanich. Accuracy is not guaranteed.

DISTRICT OF SAANICH 2017 TRAFFIC COUNTS

Major Route: Admirals Road
Minor Route: Cowper Street
Date: Tuesday, February 21, 2017
Filename: Admirals@Cowper-Feb21-2017.xls

Station #: TIN001104
Intersection Type: 3-leg east approach
East/West Route: Cowper Street
Weather: Clear and dry

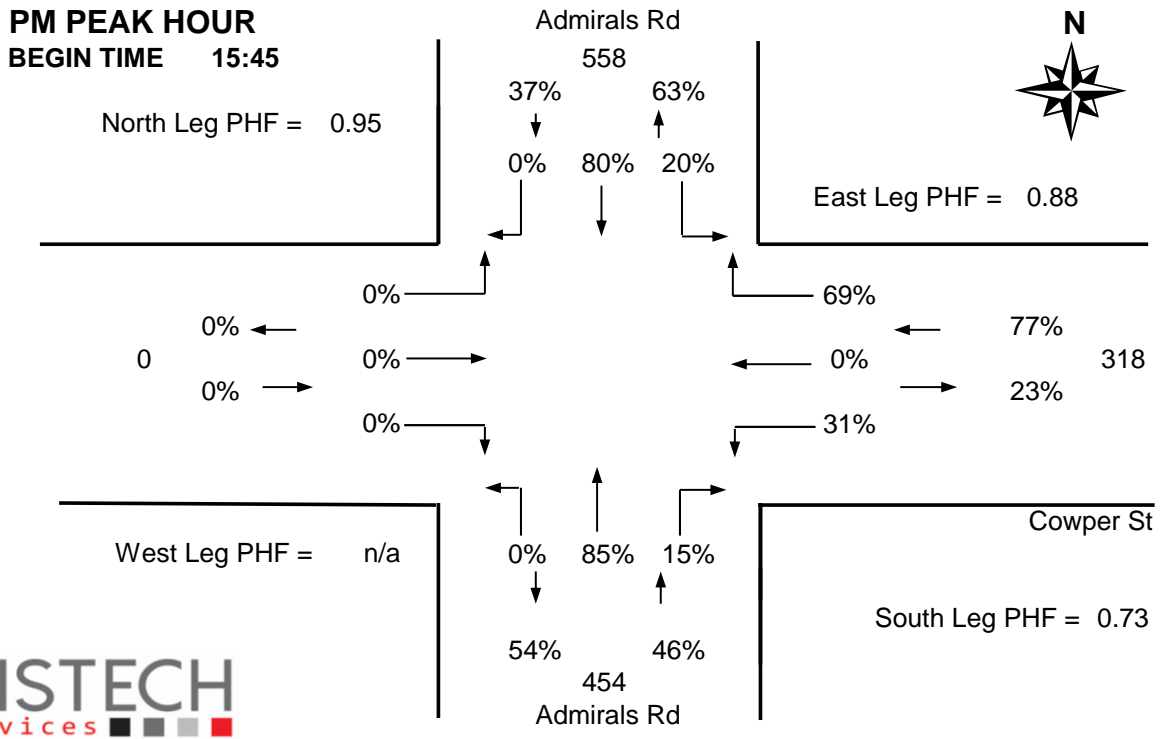
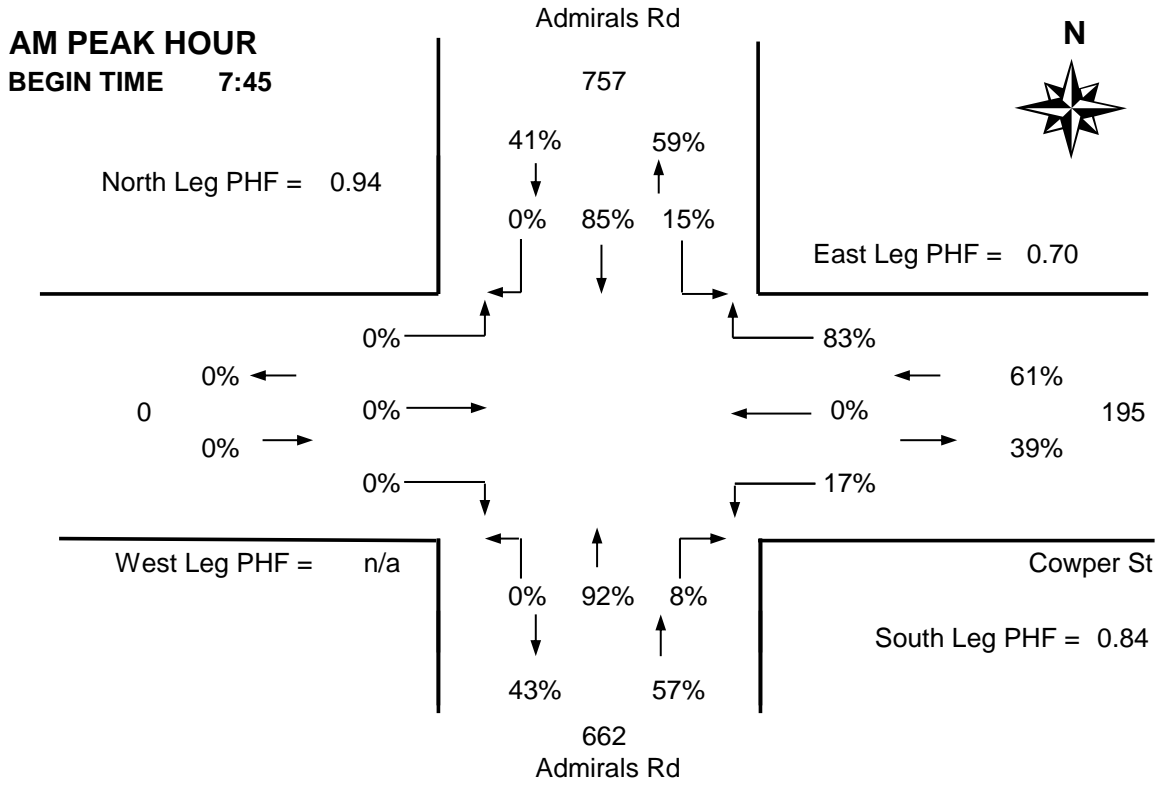

DISTRICT OF SAANICH 2017 TRAFFIC COUNTS

Major Route: Admirals Road
Minor Route: Cowper Street
Date: Tuesday, February 21, 2017
Filename: Admirals@Cowper-Feb21-2017.xls

Station #: TIN001104
Intersection Type: 3-leg east approach
East/West Route: Cowper Street
Weather: Clear and dry

Comments:

Vehicle Data

Time Period Starting	Admirals Rd			Admirals Rd			From West			Cowper St			15 Min Total	Hourly Total	Pedestrians			
	From North			From South			Left	Thru	Right	From East					N	S	W	E
	Left	Thru	Right	Left	Thru	Right				Left	Thru	Right						
7:30	10	72			72	8				4		18	184	-		0		1
7:45	9	71			86	6				3		23	198 *	-		3		2
8:00	14	56			97	7				7		35	216 +	-		2		2
8:15	12	66			97	15				3		15	208 *	806		1		0
8:30	12	71			68	2				7		25	185 *	807		0		4
8:45	14	76			72	9				8		7	186	795		0		0
9:00	12	54			78	9				1		13	167	746		0		1
9:15	12	67			56	7				6		10	158	696		2		1
Total	95	533	0	0	626	63	0	0	0	39	0	146	1502	-	0	8	0	11
Pk Hr	47	264	0	0	348	30	0	0	0	20	0	98	807 *	-	0	6	0	8
Pk Hr Factor	0.84	0.93	n/a	n/a	0.90	0.50	n/a	n/a	n/a	0.71	n/a	0.70	0.93	* = Peak hour + = Peak 15 minutes				
	0.94			0.84			n/a			0.70								
15:30	12	65			59	10				8		22	176	-		0		1
15:45	10	45			65	7				13		29	169 *	-		1		1
16:00	8	41			29	3				21		49	151 *	-		0		0
16:15	13	41			41	5				17		50	167 *	663		1		3
16:30	10	41			44	17				24		42	178 +	665		1		2
16:45	8	20			36	13				22		55	154	650		0		0
17:00	15	34			58	10				14		30	161	660		0		0
17:15	14	29			37	8				12		36	136	629		1		1
Total	90	316	0	0	369	73	0	0	0	131	0	313	1292	-	0	4	0	8
Pk Hr	41	168	0	0	179	32	0	0	0	75	0	170	665 *	-	0	3	0	6
Pk Hr Factor	0.79	0.93	n/a	n/a	0.69	0.47	n/a	n/a	n/a	0.78	n/a	0.85	0.93					
	0.95			0.73			n/a			0.88								

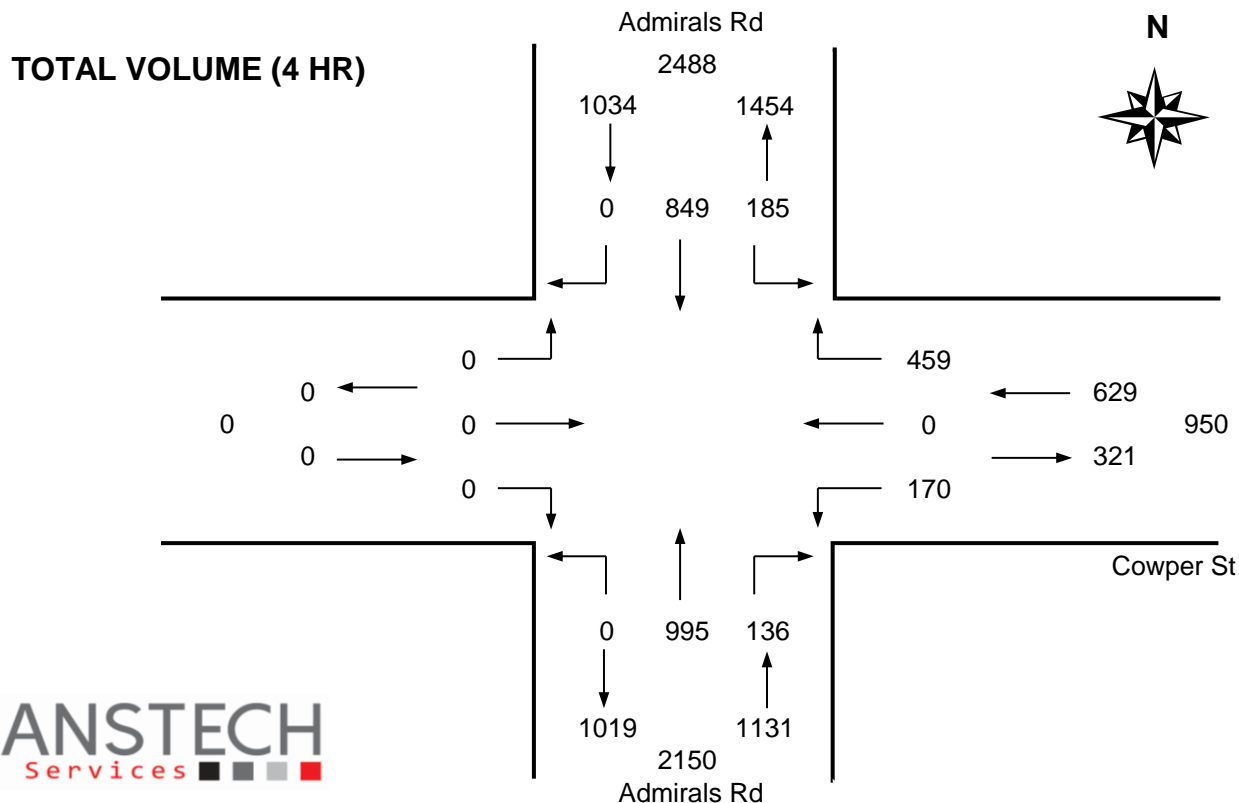

DISTRICT OF SAANICH 2017 TRAFFIC COUNTS

Major Route: Admirals Road
Minor Route: Cowper Street
Date: Tuesday, February 21, 2017
Filename: Admirals@Cowper-Feb21-2017.xls

Station #: TIN001104
Intersection Type: 3-leg east approach
East/West Route: Cowper Street
Weather: Clear and dry

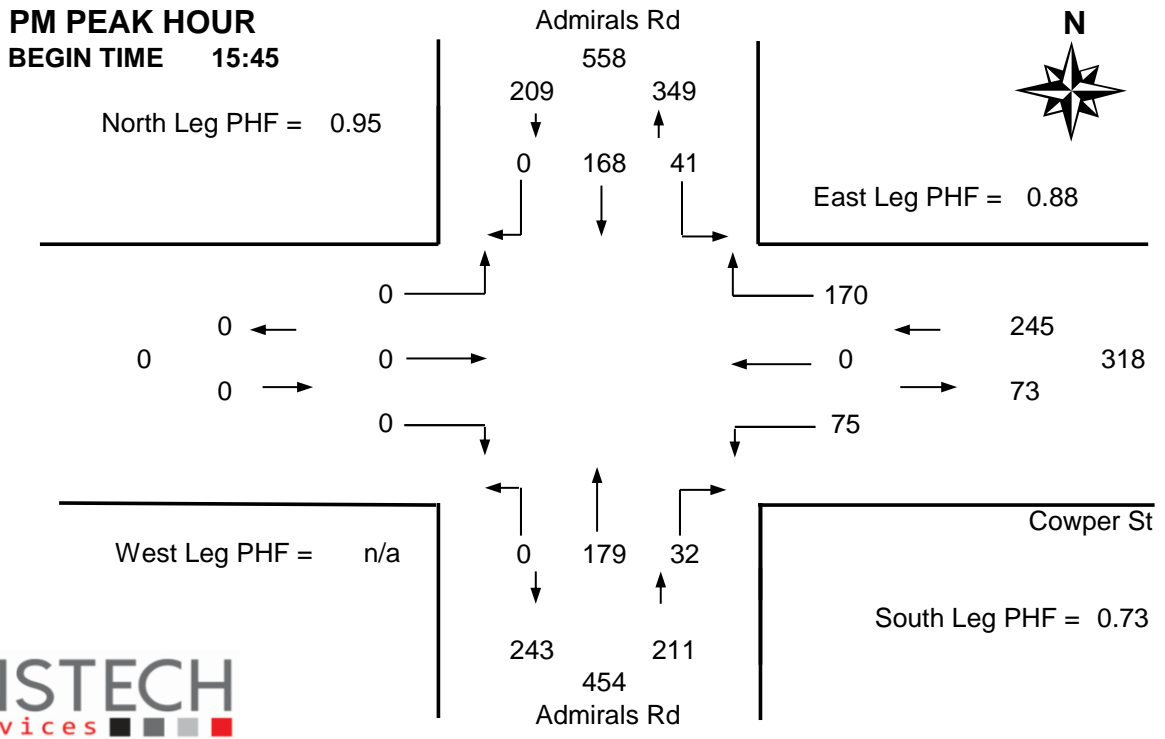
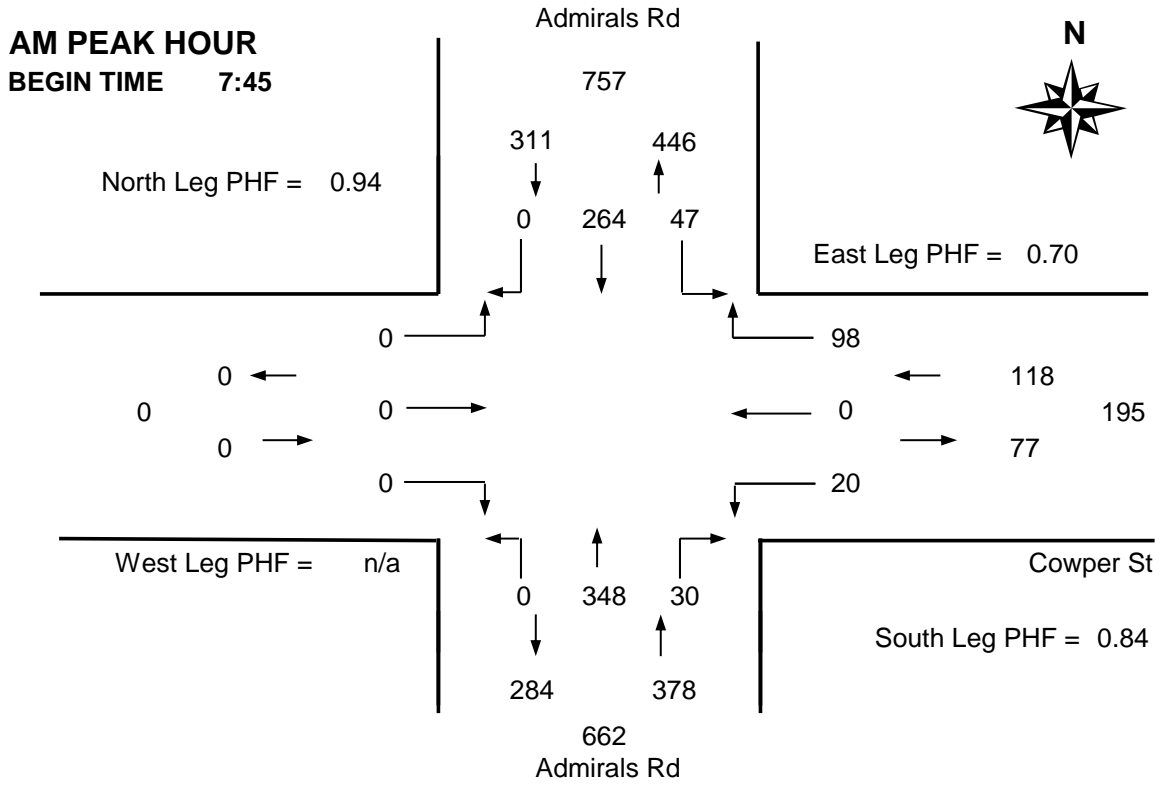

DISTRICT OF SAANICH 2017 TRAFFIC COUNTS

Major Route: Admirals Road
Minor Route: Cowper Street
Date: Tuesday, February 21, 2017
Filename: Admirals@Cowper-Feb21-2017.xls

Station #: TIN001104
Intersection Type: 3-leg east approach
East/West Route: Cowper Street
Weather: Clear and dry

Comments:

Bicycle Data

Time Period Starting	Admirals Rd			Admirals Rd			From West			Cowper St			15 Min Total	Hourly Total
	From North			From South			From West			From East				
	Left	Thru	Right	Left	Thru	Right	Left	Thru	Right	Left	Thru	Right		
7:30	0	2			5	0						0	7 +	-
7:45	0	2			3	0						1	6 *	-
8:00	0	0			4	0						0	4 *	-
8:15	0	3			2	0						0	5 *	22
8:30	0	0			1	0						0	1	16
8:45	0	0			0	0						0	0	10
9:00	0	0			2	0						0	2	8
9:15	0	0			1	0						0	1	4
Total	0	7	0	0	18	0	0	0	0	0	0	1	26	-
Pk Hr	0	7	0	0	14	0	0	0	0	0	0	1	22 *	-
15x4	0	12	0	0	16	0	0	0	0	0	0	4	32 +	-

15:30	0	1			2	0						0	3 *	-
15:45	0	0			4	0						0	4 *	-
16:00	0	2			3	0						0	5 *	-
16:15	1	1			4	0						0	6 +	18
16:30	0	0			3	0						0	3	18
16:45	1	1			0	0						0	2	16
17:00	0	2			1	0						0	3	14
17:15	1	1			2	1						0	5	13
Total	3	8	0	0	19	1	0	0	0	0	0	0	31	-
Pk Hr	1	4	0	0	13	0	0	0	0	0	0	0	18 *	-
15x4	4	8	0	0	16	0	0	0	0	0	0	0	28 +	-

4 Hr	3	15	0	0	37	1	0	0	0	0	0	0	1	57	114
------	---	----	---	---	----	---	---	---	---	---	---	---	---	----	-----

PEAK HOUR SUMMARY

